

FEATURES

- 2 synchronized DDS channels @ 500 MSPS
- Independent frequency/phase/amplitude control between channels
- Matched latencies for frequency/phase/amplitude changes
- Excellent channel-to-channel isolation (>72 dB)
- Linear frequency/phase/amplitude sweeping capability
- Up to 16 levels of frequency/phase/amplitude modulation (pin-selectable)
- 2 integrated 10-bit digital-to-analog converters (DACs)
- Individually programmable DAC full-scale currents
- 0.12 Hz or better frequency tuning resolution
- 14-bit phase offset resolution
- 10-bit output amplitude scaling resolution
- Serial I/O port interface (SPI) with 800 Mbps data throughput
- Software-/hardware-controlled power-down
- Dual supply operation (1.8 V DDS core/3.3 V serial I/O)
- Multiple device synchronization
- Selectable 4x to 20x REFCLK multiplier (PLL)
- Selectable REFCLK crystal oscillator
- 56-lead LFCSP

APPLICATIONS

- Agile local oscillators
- Phased array radars/sonars
- Instrumentation
- Synchronized clocking
- RF source for AOTF
- Single-side band suppressed carriers
- Quadrature communications

FUNCTIONAL BLOCK DIAGRAM

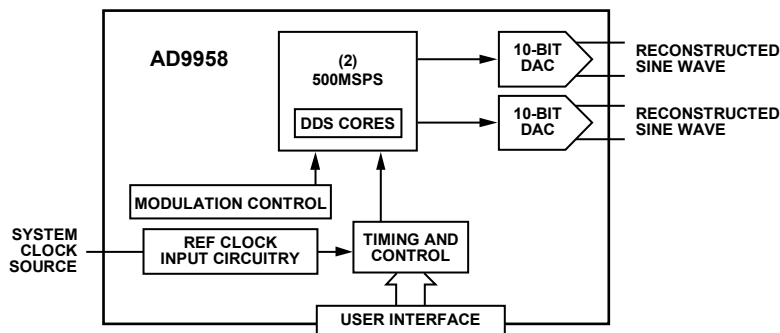

Figure 1.

06252-000

Rev. A

Information furnished by Analog Devices is believed to be accurate and reliable. However, no responsibility is assumed by Analog Devices for its use, nor for any infringements of patents or other rights of third parties that may result from its use. Specifications subject to change without notice. No license is granted by implication or otherwise under any patent or patent rights of Analog Devices. Trademarks and registered trademarks are the property of their respective owners.

TABLE OF CONTENTS

Features	1
Applications.....	1
Functional Block Diagram	1
General Description	3
Specifications.....	4
Absolute Maximum Ratings.....	8
ESD Caution.....	8
Pin Configuration and Function Descriptions.....	9
Typical Performance Characteristics	11
Application Circuits	14
Equivalent Input and Output Circuits	17
Theory of Operation	18
DDS Core.....	18
Digital-to-Analog Converter	18
Modes of Operation	19
Channel Constraint Guidelines	19
Power Supplies	19
Single-Tone Mode	19
Reference Clock Modes	20
Scalable DAC Reference Current Control Mode	21
Power-Down Functions.....	21
Modulation Mode.....	21
Modulation Using SDIO_x Pins for RU/RD.....	24

REVISION HISTORY

7/08—Rev. 0 to Rev. A

Changes to Features.....	1
Inserted Figure 1; Renumbered Sequentially.....	1
Changes to Input Level Parameter in Table 1	4
Added Profile Pin Toggle Rate Parameter in Table 1.....	6
Changes to Layout	8
Changes to Table 3.....	9
Added Equivalent Input and Output Circuits Section	17
Changes to Reference Clock Input Circuitry Section.....	20
Change to Figure 35	21
Changes to Setting the Slope of the Linear Sweep Section	25
Changes to Figure 37.....	26
Changes to Figure 38 and Figure 39.....	27
Changes to Figure 40.....	30

Linear Sweep Mode.....	25
Linear Sweep No-Dwell Mode	26
Sweep and Phase Accumulator Clearing Functions	27
Output Amplitude Control Mode.....	28
Synchronizing Multiple AD9958 Devices	29
Automatic Mode Synchronization	29
Manual Software Mode Synchronization.....	29
Manual Hardware Mode Synchronization.....	29
I/O_UPDATE, SYNC_CLK, and System Clock Relationships.....	30
Serial I/O Port.....	31
Overview	31
Instruction Byte Description	32
Serial I/O Port Pin Description.....	32
Serial I/O Port Function Description	32
MSB/LSB Transfer Description	32
Serial I/O Modes of Operation	33
Register Maps and Bit Descriptions.....	36
Register Maps.....	36
Descriptions for Control Registers	39
Descriptions for Channel Registers	41
Outline Dimensions	44
Ordering Guide	44

Added Table 25; Renumbered Sequentially	31
Changes to Figure 41.....	31
Changes to Figure 42, Serial Data I/O (SDIO_0, SDIO_1, SDIO_3) Section, and Added Example Instruction Byte Section.....	32
Added Table 27	33
Changes to Figure 46, Figure 47, Figure 48, and Figure 49.....	35
Changes to Register Maps and Bit Descriptions Section and Added Endnote 2 to Table 28.....	36
Added Endnote 1 to Table 30.....	38
Added Exposed Pad Notation to Outline Dimensions	44

9/05—Revision 0: Initial Version

GENERAL DESCRIPTION

The AD9958 consists of two DDS cores that provide independent frequency, phase, and amplitude control on each channel. This flexibility can be used to correct imbalances between signals due to analog processing, such as filtering, amplification, or PCB layout related mismatches. Because both channels share a common system clock, they are inherently synchronized. Synchronization of multiple devices is supported.

The AD9958 can perform up to a 16-level modulation of frequency, phase, or amplitude (FSK, PSK, ASK). Modulation is performed by applying data to the profile pins. In addition, the AD9958 also supports linear sweep of frequency, phase, or amplitude for applications such as radar and instrumentation.

The AD9958 serial I/O port offers multiple configurations to provide significant flexibility. The serial I/O port offers an SPI-compatible mode of operation that is virtually identical to the SPI operation found in earlier Analog Devices, Inc., DDS products. Flexibility is provided by four data pins (SDIO_0/SDIO_1/SDIO_2/SDIO_3) that allow four programmable modes of serial I/O operation.

The AD9958 uses advanced DDS technology that provides low power dissipation with high performance. The device incorporates two integrated, high speed 10-bit DACs with excellent wideband and narrow-band SFDR. Each channel has a dedicated 32-bit frequency tuning word, 14 bits of phase offset, and a 10-bit output scale multiplier.

The DAC outputs are supply referenced and must be terminated into AVDD by a resistor or an AVDD center-tapped transformer. Each DAC has its own programmable reference to enable different full-scale currents for each channel.

The DDS acts as a high resolution frequency divider with the REFCLK as the input and the DAC providing the output. The REFCLK input source is common to both channels and can be driven directly or used in combination with an integrated REFCLK multiplier (PLL) up to a maximum of 500 MSPS. The PLL multiplication factor is programmable from 4 to 20, in integer steps. The REFCLK input also features an oscillator circuit to support an external crystal as the REFCLK source. The crystal must be between 20 MHz and 30 MHz. The crystal can be used in combination with the REFCLK multiplier.

The AD9958 comes in a space-saving 56-lead LFCSP package. The DDS core (AVDD and DVDD pins) is powered by a 1.8 V supply. The digital I/O interface (SPI) operates at 3.3 V and requires the pin labeled DVDD_I/O (Pin 49) be connected to 3.3 V.

The AD9958 operates over the industrial temperature range of -40°C to $+85^{\circ}\text{C}$.

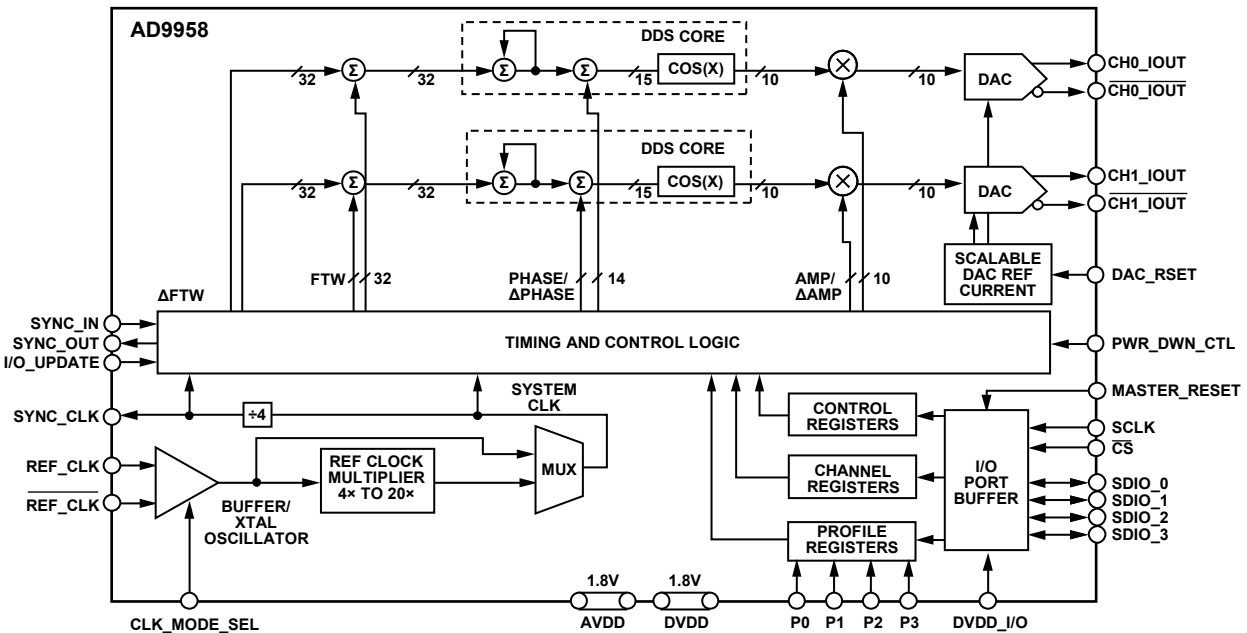

Figure 2. Detailed Block Diagram

06252-001

SPECIFICATIONS

AVDD and DVDD = 1.8 V ± 5%; DVDD_I/O = 3.3 V ± 5%; T = 25°C; R_{SET} = 1.91 kΩ; external reference clock frequency = 500 MSPS (REFCLK multiplier bypassed), unless otherwise noted.

Table 1.

Parameter	Min	Typ	Max	Unit	Test Conditions/Comments
REFERENCE CLOCK INPUT CHARACTERISTICS					
Frequency Range					See Figure 34 and Figure 35
REFCLK Multiplier Bypassed	1		500	MHz	
REFCLK Multiplier Enabled	10		125	MHz	
Internal VCO Output Frequency Range					
VCO Gain Control Bit Set High ¹	255		500	MHz	
VCO Gain Control Bit Set Low ¹	100		160	MHz	
Crystal REFCLK Source Range	20		30	MHz	
Input Level	200		1000	mV	Measured at each pin (single-ended)
Input Voltage Bias Level		1.15		V	
Input Capacitance		2		pF	
Input Impedance		1500		Ω	
Duty Cycle with REFCLK Multiplier Bypassed	45		55	%	
Duty Cycle with REFCLK Multiplier Enabled	35		65	%	
CLK Mode Select (Pin 24) Logic 1 Voltage	1.25		1.8	V	1.8 V digital input logic
CLK Mode Select (Pin 24) Logic 0 Voltage			0.5	V	1.8 V digital input logic
DAC OUTPUT CHARACTERISTICS					
Resolution			10	Bits	Must be referenced to AVDD
Full-Scale Output Current	1.25		10	mA	
Gain Error	-10		+10	% FS	
Channel-to-Channel Output Amplitude Matching Error	-2.5		+2.5	%	
Output Current Offset		1	25	μA	
Differential Nonlinearity		±0.5		LSB	
Integral Nonlinearity		±1.0		LSB	
Output Capacitance		3		pF	
Voltage Compliance Range	AVDD - 0.50		AVDD + 0.50	V	
Channel-to-Channel Isolation	72			dB	DAC supplies tied together (see Figure 19)
WIDEBAND SFDR					
1 MHz to 20 MHz Analog Output		-65		dBc	The frequency range for wideband SFDR is defined as dc to Nyquist
20 MHz to 60 MHz Analog Output		-62		dBc	
60 MHz to 100 MHz Analog Output		-59		dBc	
100 MHz to 150 MHz Analog Output		-56		dBc	
150 MHz to 200 MHz Analog Output		-53		dBc	
NARROW-BAND SFDR					
1.1 MHz Analog Output (±10 kHz)		-90		dBc	
1.1 MHz Analog Output (±50 kHz)		-88		dBc	
1.1 MHz Analog Output (±250 kHz)		-86		dBc	
1.1 MHz Analog Output (±1 MHz)		-85		dBc	
15.1 MHz Analog Output (±10 kHz)		-90		dBc	
15.1 MHz Analog Output (±50 kHz)		-87		dBc	
15.1 MHz Analog Output (±250 kHz)		-85		dBc	
15.1 MHz Analog Output (±1 MHz)		-83		dBc	
40.1 MHz Analog Output (±10 kHz)		-90		dBc	
40.1 MHz Analog Output (±50 kHz)		-87		dBc	
40.1 MHz Analog Output (±250 kHz)		-84		dBc	
40.1 MHz Analog Output (±1 MHz)		-82		dBc	
75.1 MHz Analog Output (±10 kHz)		-87		dBc	

Parameter	Min	Typ	Max	Unit	Test Conditions/Comments
75.1 MHz Analog Output (± 50 kHz)		-85		dBc	
75.1 MHz Analog Output (± 250 kHz)		-83		dBc	
75.1 MHz Analog Output (± 1 MHz)		-82		dBc	
100.3 MHz Analog Output (± 10 kHz)		-87		dBc	
100.3 MHz Analog Output (± 50 kHz)		-85		dBc	
100.3 MHz Analog Output (± 250 kHz)		-83		dBc	
100.3 MHz Analog Output (± 1 MHz)		-81		dBc	
200.3 MHz Analog Output (± 10 kHz)		-87		dBc	
200.3 MHz Analog Output (± 50 kHz)		-85		dBc	
200.3 MHz Analog Output (± 250 kHz)		-83		dBc	
200.3 MHz Analog Output (± 1 MHz)		-81		dBc	
PHASE NOISE CHARACTERISTICS					
Residual Phase Noise @ 15.1 MHz (f_{out})					
@ 1 kHz Offset		-150		dBc/Hz	
@ 10 kHz Offset		-159		dBc/Hz	
@ 100 kHz Offset		-165		dBc/Hz	
@ 1 MHz Offset		-165		dBc/Hz	
Residual Phase Noise @ 40.1 MHz (f_{out})					
@ 1 kHz Offset		-142		dBc/Hz	
@ 10 kHz Offset		-151		dBc/Hz	
@ 100 kHz Offset		-160		dBc/Hz	
@ 1 MHz Offset		-162		dBc/Hz	
Residual Phase Noise @ 75.1 MHz (f_{out})					
@ 1 kHz Offset		-135		dBc/Hz	
@ 10 kHz Offset		-146		dBc/Hz	
@ 100 kHz Offset		-154		dBc/Hz	
@ 1 MHz Offset		-157		dBc/Hz	
Residual Phase Noise @ 100.3 MHz (f_{out})					
@ 1 kHz Offset		-134		dBc/Hz	
@ 10 kHz Offset		-144		dBc/Hz	
@ 100 kHz Offset		-152		dBc/Hz	
@ 1 MHz Offset		-154		dBc/Hz	
Residual Phase Noise @ 15.1 MHz (f_{out}) with REFCLK Multiplier Enabled 5x					
@ 1 kHz Offset		-139		dBc/Hz	
@ 10 kHz Offset		-149		dBc/Hz	
@ 100 kHz Offset		-153		dBc/Hz	
@ 1 MHz Offset		-148		dBc/Hz	
Residual Phase Noise @ 40.1 MHz (f_{out}) with REFCLK Multiplier Enabled 5x					
@ 1 kHz Offset		-130		dBc/Hz	
@ 10 kHz Offset		-140		dBc/Hz	
@ 100 kHz Offset		-145		dBc/Hz	
@ 1 MHz Offset		-139		dBc/Hz	
Residual Phase Noise @ 75.1 MHz (f_{out}) with REFCLK Multiplier Enabled 5x					
@ 1 kHz Offset		-123		dBc/Hz	
@ 10 kHz Offset		-134		dBc/Hz	
@ 100 kHz Offset		-138		dBc/Hz	
@ 1 MHz Offset		-132		dBc/Hz	
Residual Phase Noise @ 100.3 MHz (f_{out}) with REFCLK Multiplier Enabled 5x					
@ 1 kHz Offset		-120		dBc/Hz	
@ 10 kHz Offset		-130		dBc/Hz	
@ 100 kHz Offset		-135		dBc/Hz	
@ 1 MHz Offset		-129		dBc/Hz	

AD9958

Parameter	Min	Typ	Max	Unit	Test Conditions/Comments
Residual Phase Noise @ 15.1 MHz (f_{OUT}) with REFCLK Multiplier Enabled 20x					
@ 1 kHz Offset		-127		dBc/Hz	
@ 10 kHz Offset		-136		dBc/Hz	
@ 100 kHz Offset		-139		dBc/Hz	
@ 1 MHz Offset		-138		dBc/Hz	
Residual Phase Noise @ 40.1 MHz (f_{OUT}) with REFCLK Multiplier Enabled 20x					
@ 1 kHz Offset		-117		dBc/Hz	
@ 10 kHz Offset		-128		dBc/Hz	
@ 100 kHz Offset		-132		dBc/Hz	
@ 1 MHz Offset		-130		dBc/Hz	
Residual Phase Noise @ 75.1 MHz (f_{OUT}) with REFCLK Multiplier Enabled 20x					
@ 1 kHz Offset		-110		dBc/Hz	
@ 10 kHz Offset		-121		dBc/Hz	
@ 100 kHz Offset		-125		dBc/Hz	
@ 1 MHz Offset		-123		dBc/Hz	
Residual Phase Noise @ 100.3 MHz (f_{OUT}) with REFCLK Multiplier Enabled 20x					
@ 1 kHz Offset		-107		dBc/Hz	
@ 10 kHz Offset		-119		dBc/Hz	
@ 100 kHz Offset		-121		dBc/Hz	
@ 1 MHz Offset		-119		dBc/Hz	
SERIAL PORT TIMING CHARACTERISTICS					
Maximum Frequency Serial Clock (SCLK)			200	MHz	
Minimum SCLK Pulse Width Low (t_{PWL})	1.6			ns	
Minimum SCLK Pulse Width High (t_{PWH})	2.2			ns	
Minimum Data Setup Time (t_{DS})	2.2			ns	
Minimum Data Hold Time	0			ns	
Minimum \overline{CS} Setup Time (t_{PRE})	1.0			ns	
Minimum Data Valid Time for Read Operation	12			ns	
MISCELLANEOUS TIMING CHARACTERISTICS					
MASTER_RESET Minimum Pulse Width	1				Min pulse width = 1 sync clock period
I/O_UPDATE Minimum Pulse Width	1				Min pulse width = 1 sync clock period
Minimum Setup Time (I/O_UPDATE to SYNC_CLK)	4.8			ns	Rising edge to rising edge
Minimum Hold Time (I/O_UPDATE to SYNC_CLK)	0			ns	Rising edge to rising edge
Minimum Setup Time (Profile Inputs to SYNC_CLK)	5.4			ns	
Minimum Hold Time (Profile Inputs to SYNC_CLK)	0			ns	
Minimum Setup Time (SDIO Inputs to SYNC_CLK)	2.5			ns	
Minimum Hold Time (SDIO Inputs to SYNC_CLK)	0			ns	
Propagation Time Between REF_CLK and SYNC_CLK	2.25	3.5	5.5	ns	
Profile Pin Toggle Rate			2	Sync clocks	
CMOS LOGIC INPUTS					
V_{IH}	2.0			V	
V_{IL}			0.8	V	
Logic 1 Current		3	12	μ A	
Logic 0 Current		-12		μ A	
Input Capacitance		2		pF	
CMOS LOGIC OUTPUTS					
V_{OH}	2.7			V	1 mA load
V_{OL}			0.4	V	

Parameter	Min	Typ	Max	Unit	Test Conditions/Comments
POWER SUPPLY					
Total Power Dissipation—Both Channels On, Single-Tone Mode		315	380	mW	Dominated by supply variation
Total Power Dissipation—Both Channels On, with Sweep Accumulator		350	420	mW	Dominated by supply variation
Total Power Dissipation—Full Power-Down		13		mW	
I _{AVDD} —Both Channels On, Single-Tone Mode		90	105	mA	
I _{AVDD} —Both Channels On, Sweep Accumulator, REFCLK Multiplier, and 10-Bit Output Scalar Enabled		95	110	mA	
I _{DVDD} —Both Channels On, Single-Tone Mode		60	70	mA	
I _{DVDD} —Both Channels On, Sweep Accumulator, REFCLK Multiplier, and 10-Bit Output Scalar Enabled		70	80	mA	
I _{DVDD,I/O}			22	mA	I _{DVDD} = read
			30	mA	I _{DVDD} = write
I _{AVDD} Power-Down Mode			2.5	mA	
I _{DVDD} Power-Down Mode			2.5	mA	
DATA LATENCY (PIPELINE DELAY) SINGLE-TONE MODE^{2,3}					
Frequency, Phase, and Amplitude Words to DAC Output with Matched Latency Enabled	29			SYCLKs	
Frequency Word to DAC Output with Matched Latency Disabled	29			SYCLKs	
Phase Offset Word to DAC Output with Matched Latency Disabled	25			SYCLKs	
Amplitude Word to DAC Output with Matched Latency Disabled	17			SYCLKs	
DATA LATENCY (PIPELINE DELAY) MODULATION MODE^{3,4}					
Frequency Word to DAC Output	34			SYCLKs	
Phase Offset Word to DAC Output	29			SYCLKs	
Amplitude Word to DAC Output	21			SYCLKs	
DATA LATENCY (PIPELINE DELAY) LINEAR SWEEP MODE^{3,4}					
Frequency Rising/Falling Delta-Tuning Word to DAC Output	41			SYCLKs	
Phase Offset Rising/Falling Delta-Tuning Word to DAC Output	37			SYCLKs	
Amplitude Rising/Falling Delta-Tuning Word to DAC Output	29			SYCLKs	

¹ For the VCO frequency range of 160 MHz to 255 MHz, there is no guarantee of operation.

² Data latency is referenced to I/O_UPDATE.

³ Data latency is fixed.

⁴ Data latency is referenced to a profile change.

ABSOLUTE MAXIMUM RATINGS

Table 2.

Parameter	Rating
Maximum Junction Temperature	150°C
DVDD_I/O (Pin 49)	4 V
AVDD, DVDD	2 V
Digital Input Voltage (DVDD_I/O = 3.3 V)	-0.7 V to +4 V
Digital Output Current	5 mA
Storage Temperature Range	-65°C to +150°C
Operating Temperature Range	-40°C to +85°C
Lead Temperature (10 sec Soldering)	300°C
θ_{JA}	21°C/W
θ_{JC}	2°C/W

Stresses above those listed under Absolute Maximum Ratings may cause permanent damage to the device. This is a stress rating only; functional operation of the device at these or any other conditions above those indicated in the operational section of this specification is not implied. Exposure to absolute maximum rating conditions for extended periods may affect device reliability.

ESD CAUTION



ESD (electrostatic discharge) sensitive device. Charged devices and circuit boards can discharge without detection. Although this product features patented or proprietary protection circuitry, damage may occur on devices subjected to high energy ESD. Therefore, proper ESD precautions should be taken to avoid performance degradation or loss of functionality.

PIN CONFIGURATION AND FUNCTION DESCRIPTIONS

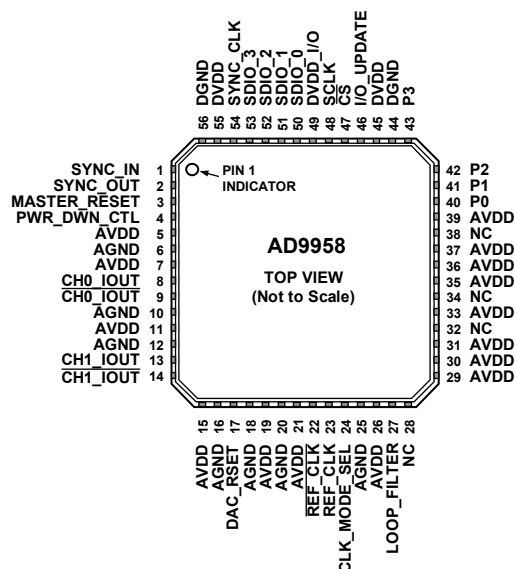

- NOTES**
1. THE EXPOSED EPAD ON BOTTOM SIDE OF PACKAGE IS AN ELECTRICAL CONNECTION AND MUST BE SOLDERED TO GROUND.
 2. PIN 49 IS DVDD_I/O AND IS TIED TO 3.3V.
 3. NC = NO CONNECT.

06262-005

Figure 3. Pin Configuration

Table 3. Pin Function Descriptions

Pin No.	Mnemonic	I/O ¹	Description
1	SYNC_IN	I	Used to Synchronize Multiple AD9958 Devices. Connects to the SYNC_OUT pin of the master AD9958 device.
2	SYNC_OUT	O	Used to Synchronize Multiple AD9958 Devices. Connects to the SYNC_IN pin of the slave AD9958 devices.
3	MASTER_RESET	I	Active High Reset Pin. Asserting the MASTER_RESET pin forces the AD9958 internal registers to their default state, as described in the Register Maps and Bit Descriptions section.
4	PWR_DWN_CTL	I	External Power-Down Control.
5, 7, 11, 15, 19, 21, 26, 29, 30, 31, 33, 35, 36, 37, 39	AVDD	I	Analog Power Supply Pins (1.8 V).
6, 10, 12, 16, 18, 20, 25	AGND	I	Analog Ground Pins.
45, 55	DVDD	I	Digital Power Supply Pins (1.8 V).
44, 56	DGND	I	Digital Power Ground Pins.
8	CH0_IOUT	O	True DAC Output. Terminates into AVDD.
9	$\overline{\text{CH0_IOUT}}$	O	Complementary DAC Output. Terminates into AVDD.
13	CH1_IOUT	O	True DAC Output. Terminates into AVDD.
14	$\overline{\text{CH1_IOUT}}$	O	Complementary DAC Output. Terminates into AVDD.
17	DAC_RSET	I	Establishes the Reference Current for All DACs. A 1.91 k Ω resistor (nominal) is connected from Pin 17 to AGND.
22	$\overline{\text{REF_CLK}}$	I	Complementary Reference Clock/Oscillator Input. When the REF_CLK is operated in single-ended mode, this pin should be decoupled to AVDD or AGND with a 0.1 μF capacitor.
23	REF_CLK	I	Reference Clock/Oscillator Input. When the REF_CLK is operated in single-ended mode, this is the input. See the Modes of Operation section for the reference clock configuration.

AD9958

Pin No.	Mnemonic	I/O ¹	Description
24	CLK_MODE_SEL	I	Control Pin for the Oscillator Section. Caution: Do not drive this pin beyond 1.8 V. When high (1.8 V), the oscillator section is enabled to accept a crystal as the REF_CLK source. When low, the oscillator section is bypassed.
27	LOOP_FILTER	I	Connects to the external zero compensation network of the PLL loop filter. Typically, the network consists of a 0 Ω resistor in series with a 680 pF capacitor tied to AVDD.
28, 32, 34, 38 40, 41, 42, 43	NC P0, P1, P2, P3	N/A I	No Connection. Data pins used for modulation (FSK, PSK, ASK), to start/stop for the sweep accumulators, or used to ramp up/ramp down the output amplitude. The data is synchronous to the SYNC_CLK (Pin 54). The data inputs must meet the setup and hold time requirements to the SYNC_CLK. The functionality of these pins is controlled by profile pin configuration (PPC) bits (FR1[14:12]).
46	I/O_UPDATE	I	A rising edge transfers data from the serial I/O port buffer to active registers. I/O_UPDATE is synchronous to the SYNC_CLK (Pin 54). I/O_UPDATE must meet the setup and hold time requirements to the SYNC_CLK to guarantee a fixed pipeline delay of data to the DAC output; otherwise, a ± 1 SYNC_CLK period of pipeline uncertainty exists. The minimum pulse width is one SYNC_CLK period.
47	\overline{CS}	I	Active Low Chip Select. Allows multiple devices to share a common I/O bus (SPI).
48	SCLK	I	Serial Data Clock for I/O Operations. Data bits are written on the rising edge of SCLK and read on the falling edge of SCLK.
49	DVDD_I/O	I	3.3 V Digital Power Supply for SPI Port and Digital I/O.
50	SDIO_0	I/O	Data Pin SDIO_0 is dedicated to the serial port I/O only.
51, 52, 53	SDIO_1, SDIO_2, SDIO_3	I/O	Data Pin SDIO_1, Data Pin SDIO_2, and Data Pin SDIO_3 can be used for the serial I/O port or used to initiate a ramp-up/ramp-down (RU/RD) of the DAC output amplitude.
54	SYNC_CLK	O	The SYNC_CLK runs at one fourth the system clock rate. It can be disabled. I/O_UPDATE or data (Pin 40 to Pin 43) is synchronous to the SYNC_CLK. To guarantee a fixed pipeline delay of data to DAC output, I/O_UPDATE or data (Pin 40 to Pin 43) must meet the setup and hold time requirements to the rising edge of SYNC_CLK; otherwise, a ± 1 SYNC_CLK period of uncertainty exists.

¹ I = input, O = output.

TYPICAL PERFORMANCE CHARACTERISTICS

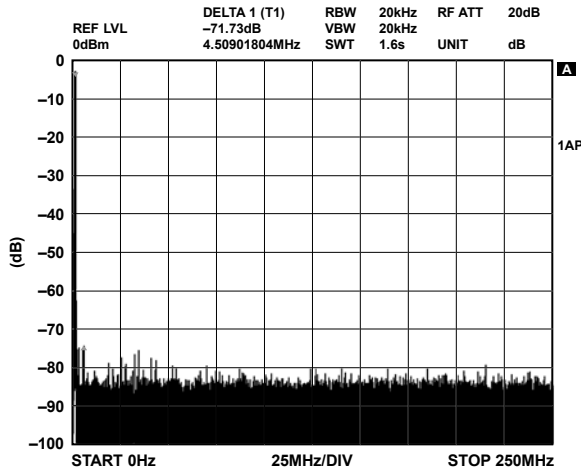

Figure 4. Wideband SFDR, $f_{OUT} = 1.1$ MHz, $f_{CLK} = 500$ MSPS

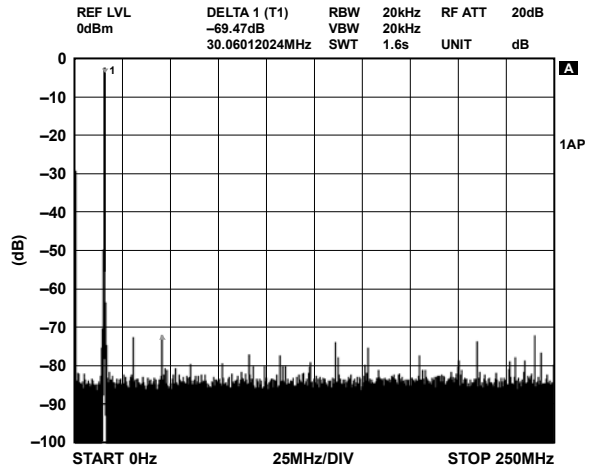

Figure 7. Wideband SFDR, $f_{OUT} = 15.1$ MHz, $f_{CLK} = 500$ MSPS

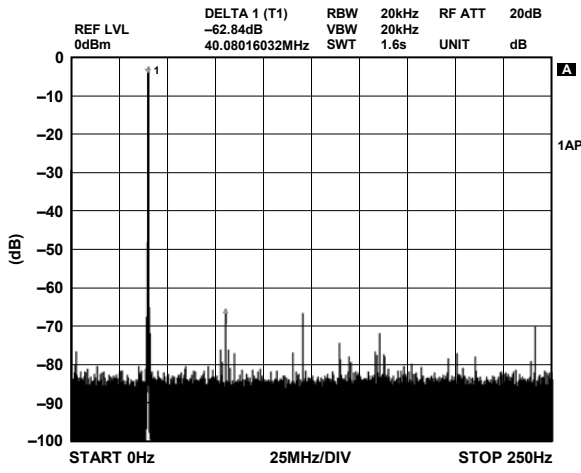

Figure 5. Wideband SFDR, $f_{OUT} = 40.1$ MHz, $f_{CLK} = 500$ MSPS

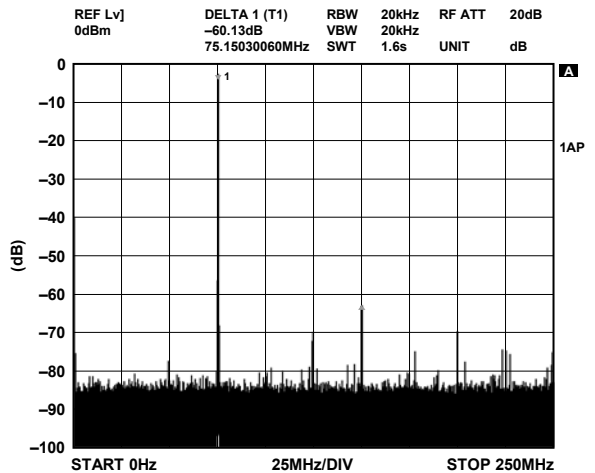

Figure 8. Wideband SFDR, $f_{OUT} = 75.1$ MHz, $f_{CLK} = 500$ MSPS

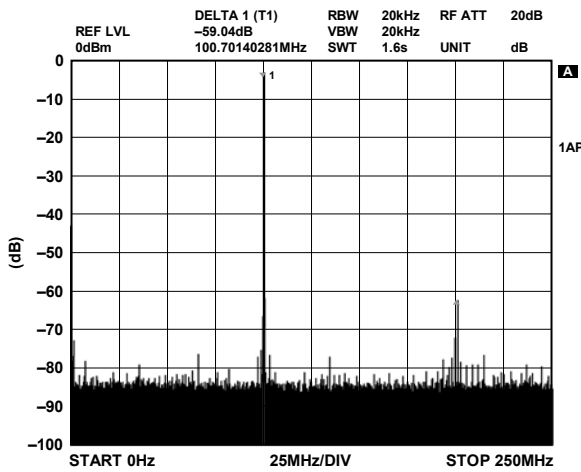

Figure 6. Wideband SFDR, $f_{OUT} = 100.3$ MHz, $f_{CLK} = 500$ MSPS

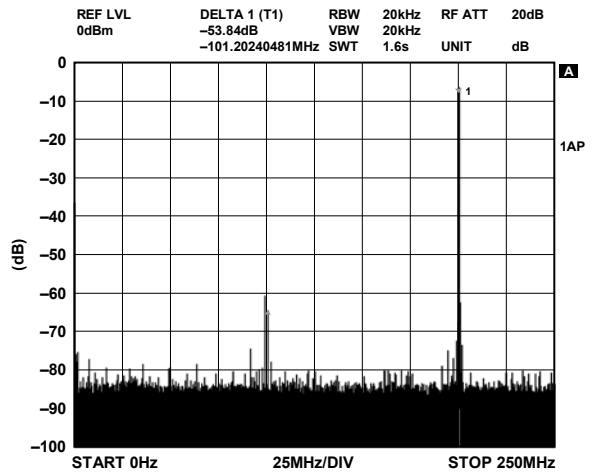

Figure 9. Wideband SFDR, $f_{OUT} = 200.3$ MHz, $f_{CLK} = 500$ MSPS

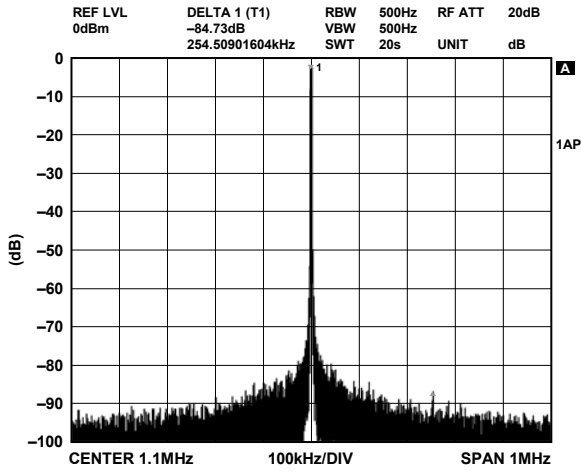

Figure 10. NBSFDR, $f_{OUT} = 1.1$ MHz, $f_{CLK} = 500$ MSPS, ± 1 MHz

05252-012

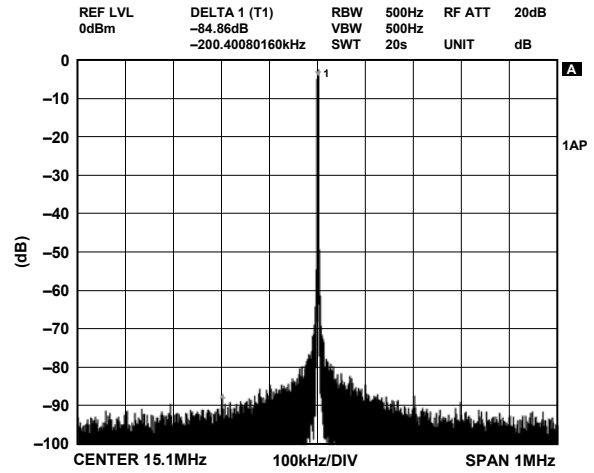

Figure 13. NBSFDR, $f_{OUT} = 15.1$ MHz, $f_{CLK} = 500$ MSPS, ± 1 MHz

05252-015

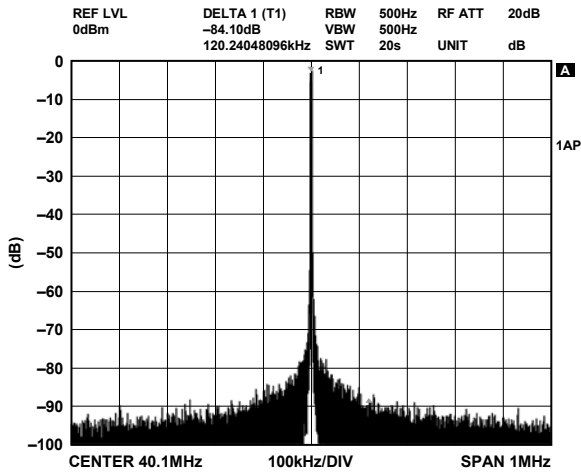

Figure 11. NBSFDR, $f_{OUT} = 40.1$ MHz, $f_{CLK} = 500$ MSPS, ± 1 MHz

05252-013

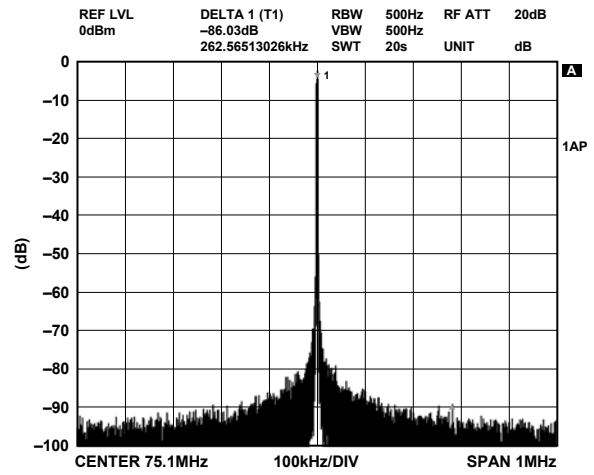

Figure 14. NBSFDR, $f_{OUT} = 75.1$ MHz, $f_{CLK} = 500$ MSPS, ± 1 MHz

05252-016

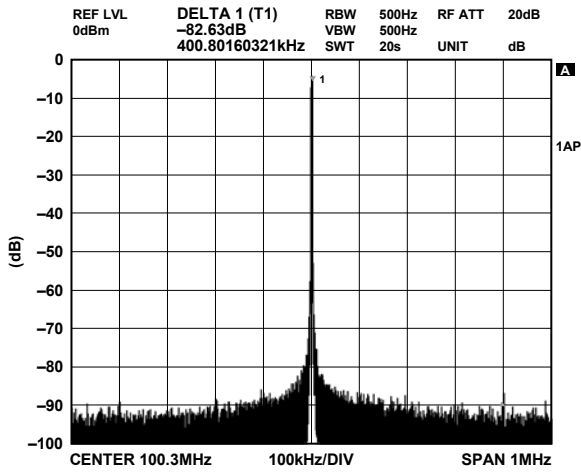

Figure 12. NBSFDR, $f_{OUT} = 100.3$ MHz, $f_{CLK} = 500$ MSPS, ± 1 MHz

05252-014

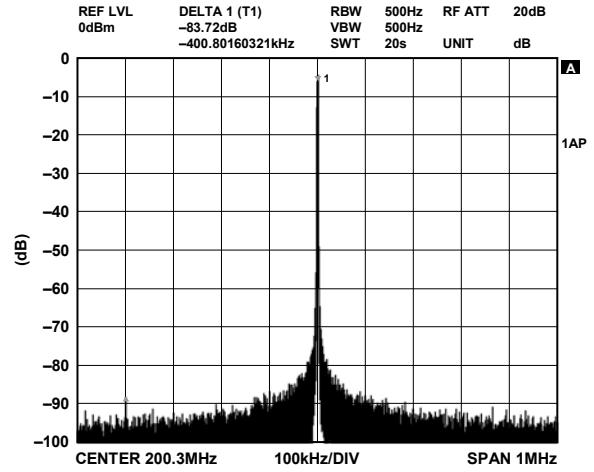

Figure 15. NBSFDR $f_{OUT} = 200.3$ MHz, $f_{CLK} = 500$ MSPS, ± 1 MHz

05252-017

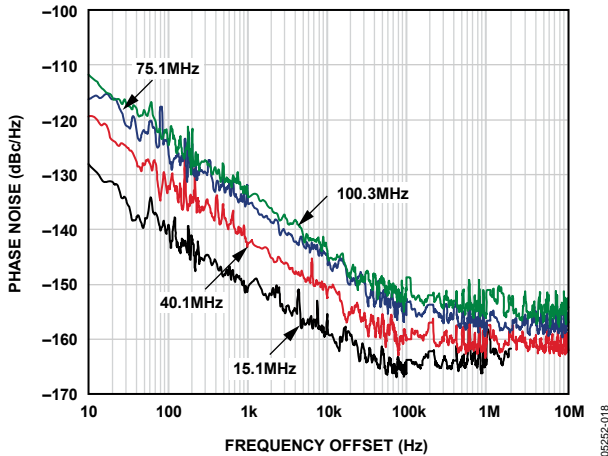

Figure 16. Residual Phase Noise (SSB) with $f_{OUT} = 15.1$ MHz, 40.1 MHz, 75.1 MHz, 100.3 MHz; $f_{CLK} = 500$ MHz with REFCLK Multiplier Bypassed

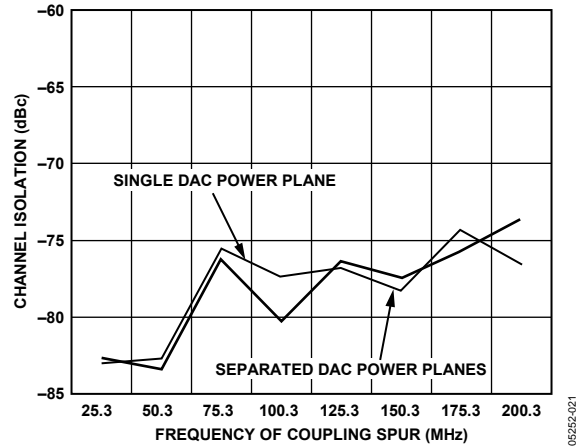

Figure 19. Channel Isolation at 500 MSPS Operation; Conditions are Channel of Interest Fixed at 110.3 MHz, the Other Channels Are Frequency Swept

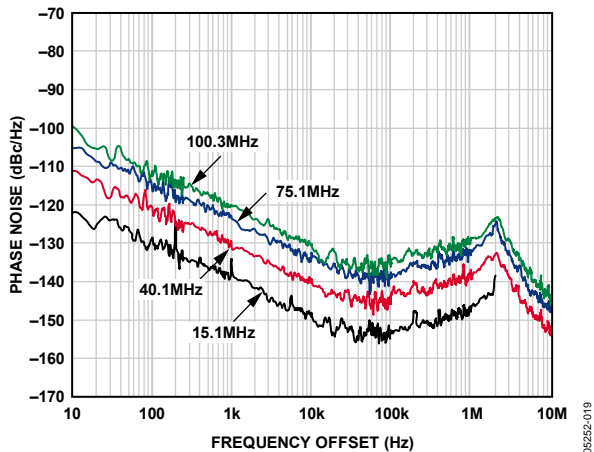

Figure 17. Residual Phase Noise (SSB) with $f_{OUT} = 15.1$ MHz, 40.1 MHz, 75.1 MHz, 100.3 MHz; $f_{CLK} = 500$ MHz with REFCLK Multiplier = 5x

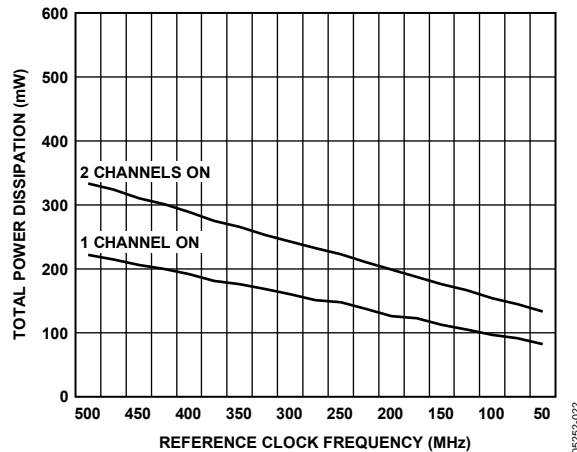

Figure 20. Power Dissipation vs. Reference Clock Frequency vs. Channel(s) Power On/Off

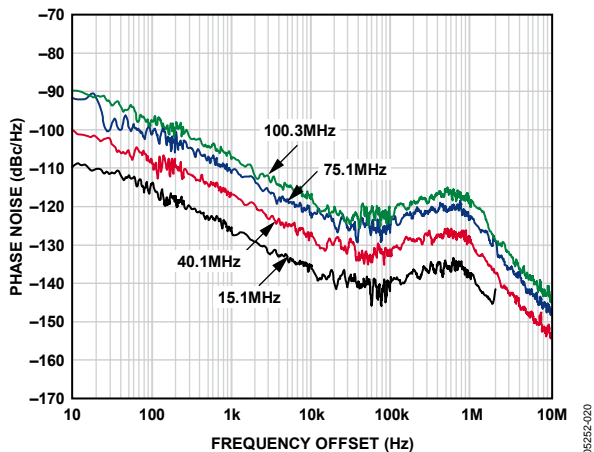

Figure 18. Residual Phase Noise (SSB) with $f_{OUT} = 15.1$ MHz, 40.1 MHz, 75.1 MHz, 100.3 MHz; $f_{CLK} = 500$ MHz with REFCLK Multiplier = 20x

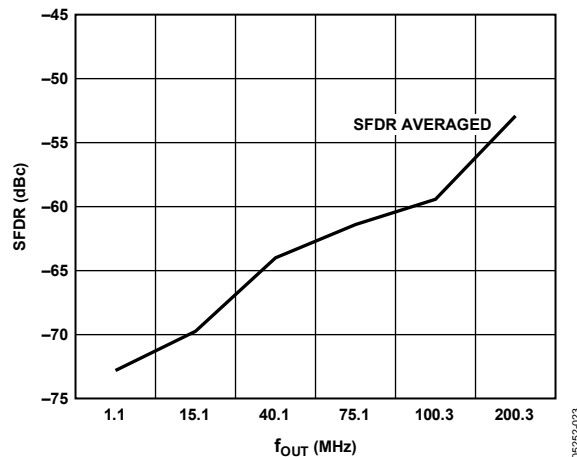

Figure 21. Averaged Channel SFDR vs. f_{OUT}

APPLICATION CIRCUITS

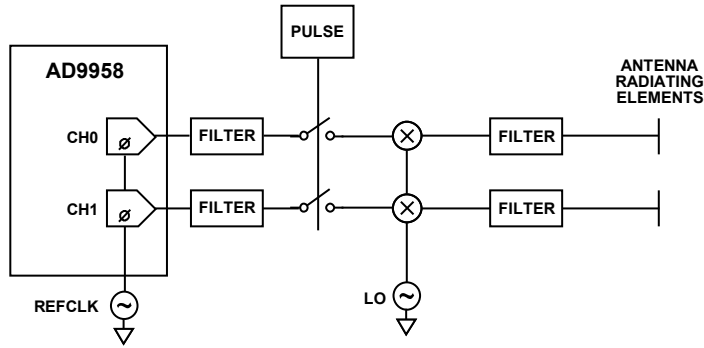

Figure 22. Phase Array Radar Using Precision Frequency/Phase Control from DDS in FMCW or Pulsed Radar Applications; DDS Provides Either Continuous Wave or Frequency Sweep

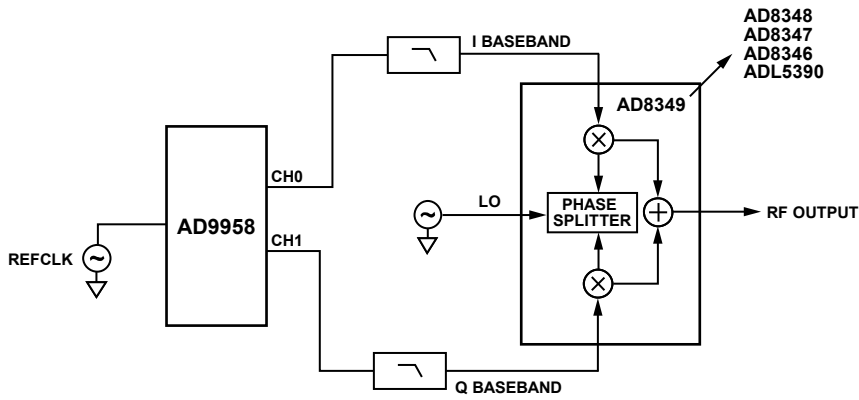

Figure 23. Single-Sideband-Suppressed Carrier Upconversion

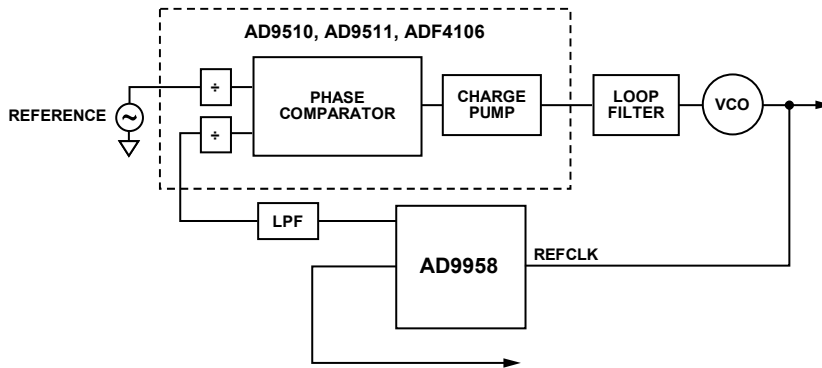

Figure 24. DDS in PLL Locking to Reference Offering Distribution with Fine Frequency and Delay Adjust Tuning

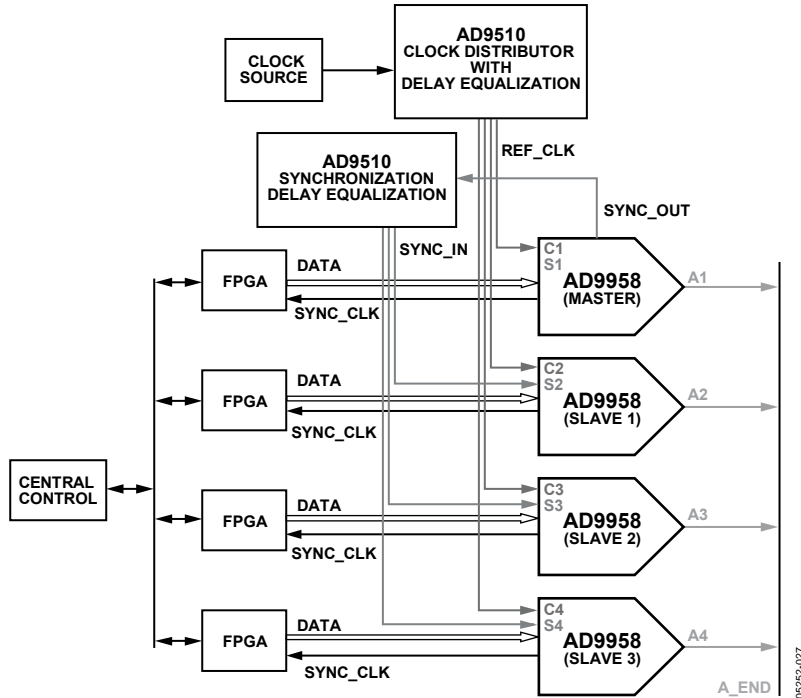

Figure 25. Synchronizing Multiple Devices to Increase Channel Capacity Using the AD9510 as a Clock Distributor for the Reference and SYNC_CLK

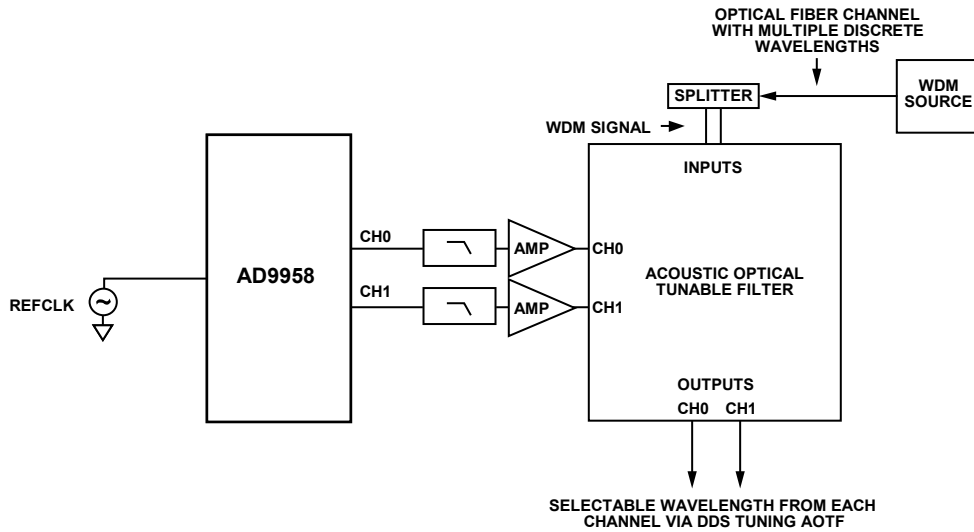

Figure 26. DDS Providing Stimulus for Acoustic Optical Tunable Filter

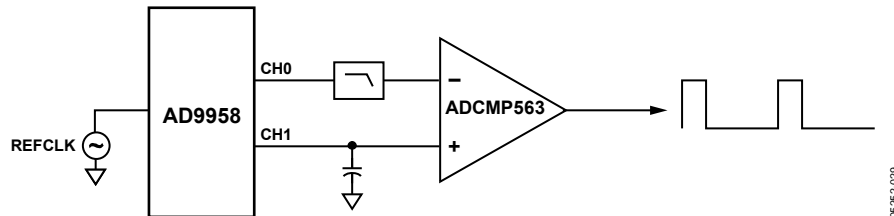

Figure 27. Agile Clock Source with Duty Cycle Control Using the Phase Offset Value in DDS to Change the DC Voltage to the Comparator

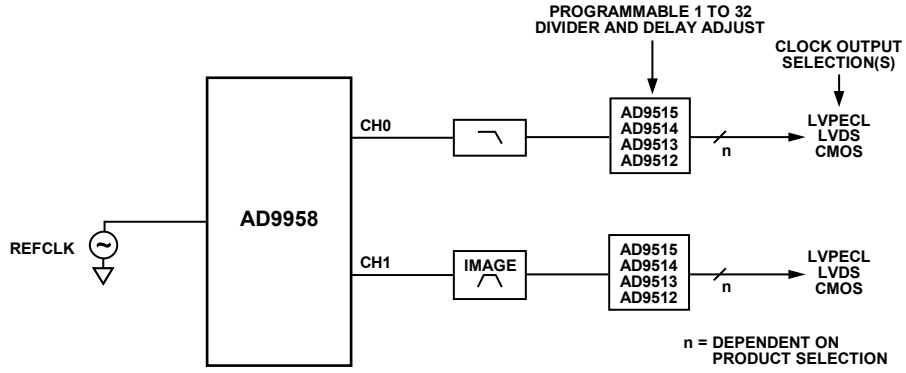
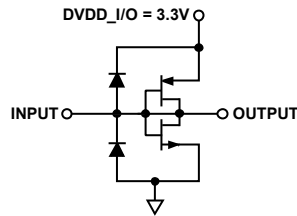

Figure 28. Clock Generation Circuit Using the AD9512/AD9513/AD9514/AD9515 Series of Clock Distribution Chips

EQUIVALENT INPUT AND OUTPUT CIRCUITS



AVOID OVERDRIVING
DIGITAL INPUTS.
FORWARD BIASING
DIODES MAY COUPLE
DIGITAL NOISE ON
POWER PINS.

05252-102

Figure 29. CMOS Digital Inputs

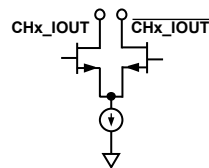

TERMINATE OUTPUTS
INTO AVDD. DO NOT
EXCEED VOLTAGE
COMPLIANCE OF
OUTPUTS.

05252-132

Figure 30. DAC Outputs

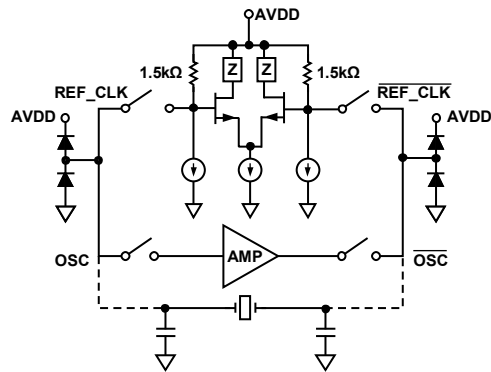

REF_CLK INPUTS ARE
INTERNALLY BIASED AND
NEED TO BE AC-COUPLED.
OSC INPUTS ARE DC-COUPLED.

05252-133

Figure 31. REF_CLK/REF_CLK Inputs

THEORY OF OPERATION

DDS CORE

The AD9958 has two DDS cores, each consisting of a 32-bit phase accumulator and phase-to-amplitude converter. Together, these digital blocks generate a digital sine wave when the phase accumulator is clocked and the phase increment value (frequency tuning word) is greater than 0. The phase-to-amplitude converter simultaneously translates phase information to amplitude information by a $\cos(\theta)$ operation.

The output frequency (f_{OUT}) of each DDS channel is a function of the rollover rate of each phase accumulator. The exact relationship is given in the following equation:

$$f_{OUT} = \frac{(FTW)(f_S)}{2^{32}}$$

where:

f_S is the system clock rate.

FTW is the frequency tuning word and is $0 \leq FTW \leq 2^{31}$.

2^{32} represents the phase accumulator capacity.

Because both channels share a common system clock, they are inherently synchronized.

The DDS core architecture also supports the capability to phase offset the output signal, which is performed by the channel phase offset word (CPOW). The CPOW is a 14-bit register that stores a phase offset value. This value is added to the output of the phase accumulator to offset the current phase of the output signal. Each channel has its own phase offset word register. This feature can be used for placing all channels in a known phase relationship relative to one another. The exact value of phase offset is given by the following equation:

$$\Phi = \left(\frac{POW}{2^{14}} \right) \times 360^\circ$$

DIGITAL-TO-ANALOG CONVERTER

The AD9958 incorporates four 10-bit current output DACs. The DAC converts a digital code (amplitude) into a discrete analog quantity. The DAC current outputs can be modeled as a current source with high output impedance (typically 100 k Ω). Unlike many DACs, these current outputs require termination into AVDD via a resistor or a center-tapped transformer for expected current flow.

Each DAC has complementary outputs that provide a combined full-scale output current ($I_{OUT} + I_{\overline{OUT}}$). The outputs always sink current, and their sum equals the full-scale current at any point in time. The full-scale current is controlled by means of an external resistor (R_{SET}) and the scalable DAC current control bits discussed in the Modes of Operation section. The resistor, R_{SET} , is connected between the DAC_RSET pin and analog ground (AGND). The full-scale current is inversely proportional to the resistor value as follows:

$$R_{SET} = \frac{18.91}{I_{OUT}(\max)}$$

The maximum full-scale output current of the combined DAC outputs is 15 mA, but limiting the output to 10 mA provides optimal spurious-free dynamic range (SFDR) performance. The DAC output voltage compliance range is AVDD + 0.5 V to AVDD - 0.5 V. Voltages developed beyond this range may cause excessive harmonic distortion. Proper attention should be paid to the load termination to keep the output voltage within its compliance range. Exceeding this range could potentially damage the DAC output circuitry.

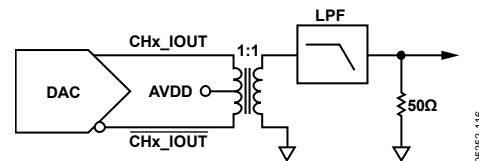

Figure 32. Typical DAC Output Termination Configuration

MODES OF OPERATION

There are many combinations of modes (for example, single-tone, modulation, linear sweep) that the AD9958 can perform simultaneously. However, some modes require multiple data pins, which can impose limitations. The following guidelines can help determine if a specific combination of modes can be performed simultaneously by the AD9958.

CHANNEL CONSTRAINT GUIDELINES

- Single-tone mode, two-level modulation mode, and linear sweep mode can be enabled on either channel and in any combination simultaneously.
- Both channels can perform four-level modulation simultaneously.
- Either channel can perform eight-level or 16-level modulation. The other channel can only be in single-tone mode.
- The RU/RD function can be used on both channels in single-tone mode. See the Output Amplitude Control Mode section for the RU/RD function.
- When Profile Pin P2 and Profile Pin P3 are used for RU/RD, either channel can perform two-level modulation with RU/RD or both channels can perform linear frequency or phase sweep with RU/RD.
- When Profile Pin P3 is used for RU/RD, either channel can be used in eight-level modulation with RU/RD. The other channel can only be in single-tone mode.
- When SDIO_1, SDIO_2, and SDIO_3 pins are used for RU/RD, either or both channels can perform two-level modulation with RU/RD. If one channel is not in two-level modulation, it can only be in single-tone mode.
- When the SDIO_1, SDIO_2, and SDIO_3 pins are used for RU/RD, either or both channels can perform four-level modulation with RU/RD. If one channel is not in four-level modulation, it can only be in single-tone mode.
- When the SDIO_1, SDIO_2, and SDIO_3 pins are used for RU/RD, either channel can perform eight-level modulation with RU/RD. The other channel can only be in single-tone mode.
- When the SDIO_1, SDIO_2, and SDIO_3 pins are used for RU/RD, either channel can perform 16-level modulation with RU/RD. The other channel can only be in single-tone mode.
- Amplitude modulation, linear amplitude sweep modes, and the RU/RD function cannot operate simultaneously, but frequency and phase modulation can operate simultaneously with the RU/RD function.

POWER SUPPLIES

The AVDD and DVDD supply pins provide power to the DDS core and supporting analog circuitry. These pins connect to a 1.8 V nominal power supply.

The DVDD_I/O pin connects to a 3.3 V nominal power supply. All digital inputs are 3.3 V logic except for the CLK_MODE_SEL input. CLK_MODE_SEL (Pin 24) is an analog input and should be operated by 1.8 V logic.

SINGLE-TONE MODE

Single-tone mode is the default mode of operation after a master reset signal. In this mode, both DDS channels share a common address location for the frequency tuning word (Register 0x04) and phase offset word (Register 0x05). Channel enable bits are provided in combination with these shared addresses. As a result, the frequency tuning word and/or phase offset word can be independently programmed between channels (see the following Step 1 through Step 5). The channel enable bits do not require an I/O update to enable or disable a channel.

See the Register Maps and Bit Descriptions section for a description of the channel enable bits in the channel select register (CSR, Register 0x00). The channel enable bits are enabled or disabled immediately after the CSR data byte is written.

Address sharing enables channels to be written simultaneously, if desired. The default state enables all channel enable bits. Therefore, the frequency tuning word and/or phase offset word is common to all channels but written only once through the serial I/O port.

The following steps present a basic protocol to program a different frequency tuning word and/or phase offset word for each channel using the channel enable bits.

1. Power up the DUT and issue a master reset. A master reset places the part in single-tone mode and single-bit mode for serial programming operations (refer to the Serial I/O Modes of Operation section). Frequency tuning words and phase offset words default to 0 at this point.
2. Enable only one channel enable bit (Register 0x00) and disable the other channel enable bit.
3. Using the serial I/O port, program the desired frequency tuning word (Register 0x04) and/or the phase offset word (Register 0x05) for the enabled channel.
4. Repeat Step 2 and Step 3 for each channel.
5. Send an I/O update signal. After an I/O update, all channels should output their programmed frequency and/or phase offset values.

Single-Tone Mode—Matched Pipeline Delay

In single-tone mode, the AD9958 offers matched pipeline delay to the DAC input for all frequency, phase, and amplitude changes. This avoids having to deal with different pipeline delays between the three input ports for such applications. The feature is enabled by asserting the matched pipe delays active bit found in the channel function register (CFR, Register 0x03). This feature is available in single-tone mode only.

REFERENCE CLOCK MODES

The AD9958 supports multiple reference clock configurations to generate the internal system clock. As an alternative to clocking the part directly with a high frequency clock source, the system clock can be generated using the internal, PLL-based reference clock multiplier. An on-chip oscillator circuit is also available for providing a low frequency reference signal by connecting a crystal to the clock input pins. Enabling these features allows the part to operate with a low frequency clock source and still provide a high update rate for the DDS and DAC. However, using the clock multiplier changes the output phase noise characteristics. For best phase noise performance, a clean, stable clock with a high slew is required (see Figure 17 and Figure 18).

Enabling the PLL allows multiplication of the reference clock frequency from 4× to 20×, in integer steps. The PLL multiplication value is represented by a 5-bit multiplier value. These bits are located in Function Register 1 (FR1, Register 0x01), Bits[22:18] (see the Register Maps and Bit Descriptions section).

When FR1[22:18] is programmed with values ranging from 4 to 20 (decimal), the clock multiplier is enabled. The integer value in the register represents the multiplication factor. The system clock rate with the clock multiplier enabled is equal to the reference clock rate multiplied by the multiplication factor. If FR1[22:18] is programmed with a value less than 4 or greater than 20, the clock multiplier is disabled and the multiplication factor is effectively 1.

Whenever the PLL clock multiplier is enabled or the multiplication value is changed, time should be allowed to lock the PLL (typically 1 ms).

Note that the output frequency of the PLL is restricted to a frequency range of 100 MHz to 500 MHz. However, there is a VCO gain control bit that must be used appropriately. The VCO gain control bit defines two ranges (low/high) of frequency output. The VCO gain control bit defaults to low (see Table 1 for details).

Table 4. Clock Configuration

CLK_MODE_SEL, Pin 24	FR1[22:18] PLL Divider Ratio = M	Crystal Oscillator Enabled	System Clock (f_{SYSCLK})	Min/Max Freq. Range (MHz)
High = 1.8 V Logic	$4 \leq M \leq 20$	Yes	$f_{\text{SYSCLK}} = f_{\text{OSC}} \times M$	$100 < f_{\text{SYSCLK}} < 500$
High = 1.8 V Logic	$M < 4$ or $M > 20$	Yes	$f_{\text{SYSCLK}} = f_{\text{OSC}}$	$20 < f_{\text{SYSCLK}} < 30$
Low	$4 \leq M \leq 20$	No	$f_{\text{SYSCLK}} = f_{\text{REFCLK}} \times M$	$100 < f_{\text{SYSCLK}} < 500$
Low	$M < 4$ or $M > 20$	No	$f_{\text{SYSCLK}} = f_{\text{REFCLK}}$	$0 < f_{\text{SYSCLK}} < 500$

The charge pump current in the PLL defaults to 75 μA . This setting typically produces the best phase noise characteristics. Increasing the charge pump current may degrade phase noise, but it decreases the lock time and changes the loop bandwidth.

Enabling the on-chip oscillator for crystal operation is performed by driving CLK_MODE_SEL (Pin 24) to logic high (1.8 V logic). With the on-chip oscillator enabled, connection of an external crystal to the REF_CLK and REF_CLK inputs is made, producing a low frequency reference clock. The frequency of the crystal must be in the range of 20 MHz to 30 MHz.

Table 4 summarizes the clock modes of operation. See Table 1 for more details.

Reference Clock Input Circuitry

The reference clock input circuitry has two modes of operation controlled by the logic state of Pin 24 (CLK_MODE_SEL). The first mode (logic low) configures as an input buffer. In this mode, the reference clock must be ac-coupled to the input due to internal dc biasing. This mode supports either differential or single-ended configurations. If single-ended mode is chosen, the complementary reference clock input (Pin 22) should be decoupled to AVDD or AGND via a 0.1 μF capacitor. Figure 33 to Figure 35 exemplify typical reference clock configurations for the AD9958.

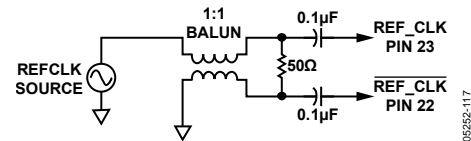

Figure 33. Differential Coupling from Single-Ended Source

The reference clock inputs can also support an LVPECL or PECL driver as the reference clock source.

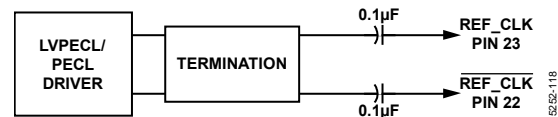

Figure 34. Differential Clock Source Hook-Up

The second mode of operation (Pin 24 = logic high = 1.8 V) provides an internal oscillator for crystal operation. In this mode, both clock inputs are dc-coupled via the crystal leads and are bypassed. The range of crystal frequencies supported is from 20 MHz to 30 MHz. Figure 35 shows the configuration for using a crystal.

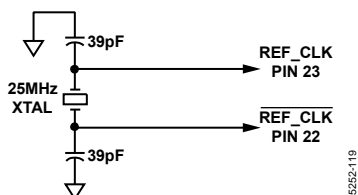

Figure 35. Crystal Input Configuration

SCALABLE DAC REFERENCE CURRENT CONTROL MODE

R_{SET} is common to all four DACs. As a result, the full-scale currents are equal by default. The scalable DAC reference can be used to set the full-scale current of each DAC independent from one another. This is accomplished by using the register bits CFR[9:8]. Table 5 shows how each DAC can be individually scaled for independent channel control. This scaling provides for binary attenuation.

Table 5. DAC Full-Scale Current Control

CFR[9:8]	LSB Current State
11	Full scale
01	Half scale
10	Quarter scale
00	Eighth scale

POWER-DOWN FUNCTIONS

The AD9958 supports an externally controlled power-down feature and the more common software programmable power-down bits found in previous Analog Devices DDS products.

The software control power-down allows the input clock circuitry, the DAC, and the digital logic (for each separate channel) to be individually powered down via unique control bits (CFR[7:6]). These bits are not active when the externally controlled power-down pin (PWR_DWN_CTL) is high. When the input pin, PWR_DWN_CTL, is high, the AD9958 enters a power-down mode based on the FR1[6] bit. When the PWR_DWN_CTL input pin is low, the external power-down control is inactive.

When FR1[6] = 0 and the PWR_DWN_CTL input pin is high, the AD9958 is put into a fast recovery power-down mode. In this mode, the digital logic and the DAC digital logic are powered down. The DAC bias circuitry, PLL, oscillator, and clock input circuitry are not powered down.

When FR1[6] = 1 and the PWR_DWN_CTL input pin is high, the AD9958 is put into full power-down mode. In this mode, all functions are powered down. This includes the DAC and PLL, which take a significant amount of time to power up. When the PLL is bypassed, the PLL is shut down to conserve power.

When the PWR_DWN_CTL input pin is high, the individual power-down bits (CFR[7:6]) and (FR1[7]) are invalid (don't care) and unused. When the PWR_DWN_CTL input pin is low, the individual power-down bits control the power-down modes of operation.

Note that the power-down signals are all designed such that Logic 1 indicates the low power mode and Logic 0 indicates the powered-up mode.

MODULATION MODE

The AD9958 can perform 2-/4-/8-/16-level modulation of frequency, phase, or amplitude. Modulation is achieved by applying data to the profile pins. Each channel can be programmed separately, but the ability to modulate multiple channels simultaneously is constrained by the limited number of profile pins. For instance, 16-level modulation uses all four profile pins, which inhibits modulation for the remaining channel.

In addition, the AD9958 has the ability to ramp up or ramp down the output amplitude before, during, or after a modulation (FSK, PSK only) sequence. This is performed by using the 10-bit output scalar. If the RU/RD feature is desired, unused profile pins or unused SDIO_1/SDIO_2/SDIO_3 pins can be configured to initiate the operation. See the Output Amplitude Control Mode section for more details of the RU/RD feature.

In modulation mode, each channel has its own set of control bits to determine the type (frequency, phase, or amplitude) of modulation. Each channel has 16 profile (channel word) registers for flexibility. Register 0x0A through Register 0x18 are profile registers for modulation of frequency, phase, or amplitude. Register 0x04, Register 0x05, and Register 0x06 are dedicated registers for frequency, phase, and amplitude, respectively. These registers contain the first frequency, phase offset, and amplitude word.

Frequency modulation has 32-bit resolution, phase modulation is 14 bits, and amplitude is 10 bits. When modulating phase or amplitude, the word value must be MSB aligned in the profile (channel word) registers and the unused bits are don't care bits.

In modulation mode, the amplitude frequency phase (AFP) select bits (CFR[23:22]) and modulation level bits (FR1[9:8]) are programmed to configure the modulation type and level (see Table 6 and Table 7). Note that the linear sweep enable bit must be set to Logic 0 in direct modulation mode.

Table 6. Modulation Type Configuration

AFP Select (CFR[23:22])	Linear Sweep Enable (CFR[14])	Description
00	X	Modulation disabled
01	0	Amplitude modulation
10	0	Frequency modulation
11	0	Phase modulation

Table 7. Modulation Level Selection

Modulation Level (FR1[9:8])	Description
00	Two-level modulation
01	Four-level modulation
10	Eight-level modulation
11	16-level modulation

When modulating, the RU/RD function can be limited based on pins available for controlling the feature. The SDIO_x pins are for RU/RD only, not for modulation.

Table 8. RU/RD Profile Pin Assignments

Ramp-Up/Ramp-Down (RU/RD) (FR1[11:10])	Description
00	RU/RD disabled
01	Only Profile Pin P2 and Profile Pin P3 available for RU/RD operation
10	Only Profile Pin P3 available for RU/RD operation
11	Only SDIO_1, SDIO_2, and SDIO_3 pins available for RU/RD operation; this forces the serial I/O to be used only in 1-bit mode

Table 9. Profile Pin Channel Assignments

Profile Pin Configuration (PPC) (FR1[14:12])	P0	P1	P2	P3	Description
XXX	N/A	N/A	CH0	CH1	Two-level modulation, both channels, no RU/RD

Table 10. Profile Pin and Channel Assignments

Profile Pin Configuration (PPC) (FR1[14:12])	P0	P1	P2	P3	Description
101	CH0	CH0	CH1	CH1	Four-level modulation on CH0 and CH1, no RU/RD

If the profile pins are used for RU/RD, Logic 0 is for ramp-up and Logic 1 is for ramp-down.

Because of the two channels and limited data pins, it is necessary to assign the profile pins and/or SDIO_1, SDIO_2, and SDIO_3 pins to a dedicated channel. This is controlled by the profile pin configuration (PPC) bits (FR1[14:12]). Each of the following modulation descriptions incorporates data pin assignments.

Two-Level Modulation—No RU/RD

The modulation level bits (FR1[9:8]) are set to 00 (two-level). The AFP select bits (CFR[23:22]) are set to the desired modulation type. The RU/RD bits (FR1[11:10]) and the linear sweep enable bit (CFR[14]) are disabled. Table 9 displays how the profile pins and channels are assigned.

As shown in Table 9, only Profile Pin P2 can be used to modulate Channel 0. If frequency modulation is selected and Profile Pin P2 is Logic 0, Channel Frequency Tuning Word 0 (Register 0x04) is chosen; if Profile Pin P2 is Logic 1, Channel Word 1 (Register 0x0A) is chosen.

Four-Level Modulation—No RU/RD

The modulation level bits are set to 01 (four-level). The AFP select bits (CFR[23:22]) are set to the desired modulation type. The RU/RD bits (FR1[11:10]) and the linear sweep enable bit (CFR[14]) are disabled. Table 10 displays how the profile pins and channels are assigned to each other.

For the conditions in Table 10, the profile (channel word) register chosen is based on the 2-bit value presented to Profile Pins [P0:P1] or Profile Pins [P2:P3].

For example, if PPC = 101, [P0:P1] = 11, and [P2:P3] = 01, then the contents of the Channel Word 3 register of Channel 0 are presented to the output of Channel 0 and the contents of the Channel Word 1 register of Channel 1 are presented to the output of Channel 1.

Eight-Level Modulation—No RU/RD

The modulation level bits (FR1[9:8]) are set to 10 (eight-level). The AFP select bits (CFR[23:22]) are set to a nonzero value. The RU/RD bits (FR1[11:10]) and the linear sweep enable bit (CFR[14]) are disabled. Note that the AFP select bits of the other channel not being used must be set to 00. Table 11 shows the assignment of profile pins and channels.

For the condition in Table 11, the choice of channel word registers is based on the 3-bit value presented to Profile Pins [P0:P2]. For example, if PPC = X10 and [P0:P2] = 111, the contents of the Channel Word 7 register of Channel 0 are presented to the output Channel 0.

16-Level Modulation—No RU/RD

The modulation level bits (FR1[9:8]) are set to 11 (16-level). The AFP select bits (CFR[23:22]) are set to the desired modulation type. The RU/RD bits (FR1[11:10]) and the linear sweep enable bit (CFR[14]) are disabled. The AFP select bits of the other channel not being used must be set to 00. Table 12 displays how the profile pins and channels are assigned.

Table 11. Profile Pin and Channel Assignments for Eight-Level Modulation (No RU/RD)

Profile Pin Config. (PPC) (FR1[14:12])	P0	P1	P2	P3	Description
X10	CH0	CH0	CH0	X	Eight-level modulation on CH0, no RU/RD
X11	CH1	CH1	CH1	X	Eight-level modulation on CH1, no RU/RD

Table 12. Profile Pin and Channel Assignments for 16-Level Modulation (No RU/RD)

Profile Pin Config. (PPC) (FR1[14:12])	P0	P1	P2	P3	Description
X10	CH0	CH0	CH0	CH0	16-level modulation on CH0, no RU/RD
X11	CH1	CH1	CH1	CH1	16-level modulation on CH1, no RU/RD

Table 13. Profile Pin and Channel Assignments for Two-Level Modulation (RU/RD Enabled)

Profile Pin Config. (PPC) (FR1[14:12])	P0	P1	P2	P3	Description
101	CH0	CH1	CH0 RU/RD	CH1 RU/RD	Two-level modulation on CH0 and CH1 with RU/RD

Table 14. Profile Pin and Channel Assignments for Eight-Level Modulation (RU/RD Enabled)

Profile Pin Config. (PPC) (FR1[14:12])	P0	P1	P2	P3	Description
X10	CH0	CH0	CH0	CH0 RU/RD	Eight-level modulation on CH0 with RU/RD
X11	CH1	CH1	CH1	CH1 RU/RD	Eight-level modulation on CH1 with RU/RD

For the conditions in Table 12, the profile register chosen is based on the 4-bit value presented to Profile Pins [P0:P3]. For example, if PPC = X11 and [P0:P3] = 1110, the contents of the Channel Word 14 register of Channel 1 is presented to the output of Channel 1.

Two-Level Modulation Using Profile Pins for RU/RD

When the RU/RD bits = 01, Profile Pin P2 and Profile Pin P3 are available for RU/RD. Note that only a modulation level of two is available in this mode. See Table 13 for available pin assignments.

Eight-Level Modulation Using a Profile Pin for RU/RD

When the RU/RD bits = 10, Profile Pin P3 is available for RU/RD. Note that only a modulation level of eight is available in this mode. See Table 14 for available pin assignments.

MODULATION USING SDIO_x PINS FOR RU/RD

For RU/RD bits = 11, the SDIO_1, SDIO_2, and SDIO_3 pins are available for RU/RD. In this mode, modulation levels of 2, 4, and 16 are available. Note that the serial I/O port can be used only in 1-bit serial mode.

Two-Level Modulation Using SDIO Pins for RU/RD

Table 15. Profile Pin and Channel Assignments in Two-Level Modulation (RU/RD Enabled)

Profile Pin Config. (PPC) (FR1[14:12])	P0	P1	P2	P3
XXX	N/A	N/A	CH0	CH1

For the configuration in Table 15, each profile pin is dedicated to a specific channel. In this case, the SDIO_x pins can be used for the RU/RD function, as described in Table 16.

Four-Level Modulation Using SDIO Pins for RU/RD

For RU/RD bits = 11 (the SDIO_1 and SDIO_2 pins are available for RU/RD), the modulation level is set to 4. See Table 17 for pin assignments, including SDIO_x pin assignments.

Table 16. Channel and SDIO_1/SDIO_2/SDIO_3 Pin Assignments for RU/RD Operation

SDIO_1	SDIO_2	SDIO_3	Description
1	0	0	Triggers the ramp-up function for CH0
1	0	1	Triggers the ramp-down function for CH0
1	1	0	Triggers the ramp-up function for CH1
1	1	1	Triggers the ramp-down function for CH1

Table 17. Channel and Profile Pin Assignments, Including SDIO_1/SDIO_2/SDIO_3 Pin Assignments for RU/RD Operation

Profile Pin Configuration (PPC) (FR1[14:12])	P0	P1	P2	P3	SDIO_1	SDIO_2	SDIO_3
101	CH0	CH0	CH1	CH1	CH0 RU/RD	CH1 RU/RD	N/A

Table 18. Channel and Profile Pin Assignments, Including SDIO_1 Pin Assignments for RU/RD Operation

Profile Pin Configuration (PPC) (FR1[14:12])	P0	P1	P2	P3	SDIO_1	SDIO_2	SDIO_3
X10	CH0	CH0	CH0	CH0	CH0 RU/RD	N/A	N/A
X11	CH1	CH1	CH1	CH1	CH1 RU/RD	N/A	N/A

For the configuration shown in Table 17, the profile (channel word) register is chosen based on the 2-bit value presented to Profile Pins [P1:P2] or [P3:P4].

For example, if PPC = 101, [P0:P1] = 11, and [P2:P3] = 01, the contents of the Channel Word 3 register of Channel 0 are presented to the output of Channel 0 and the contents of the Channel Word 1 register of Channel 1 are presented to the output of Channel 1. SDIO_1 and SDIO_2 provide the RU/RD function.

16-Level Modulation Using SDIO Pins for RU/RD

The RU/RD bits = 11 (SDIO_1 available for RU/RD), and the level is set to 16. See the pin assignments shown in Table 18.

For the configuration shown in Table 18, the profile (channel word) register is chosen based on the 4-bit value presented to Profile Pins [P0:P3]. For example, if PPC = X10 and [P0:P3] = 1101, then the contents of the Channel Word 13 register of Channel 0 is presented to the output of Channel 0. The SDIO_1 pin provides the RU/RD function.

LINEAR SWEEP MODE

Linear sweep mode enables the user to sweep frequency, phase, or amplitude from a starting point (S0) to an endpoint (E0). The purpose of linear sweep mode is to provide better bandwidth containment compared to direct modulation by replacing greater instantaneous changes with more gradual, user-defined changes between S0 and E0.

In linear sweep mode, S0 is loaded into the Channel Word 0 register (S0 is represented by one of three registers: Register 0x04, Register 0x05, or Register 0x06, depending on the type of sweep) and E0 is always loaded into Channel Word 1 (Register 0x0A). If E0 is configured for frequency sweep, the resolution is 32 bits, phase sweep is 14 bits, and amplitude sweep is 10 bits. When sweeping phase or amplitude, the word value must be MSB aligned in the Channel Word 1 register. The unused bits don't care bits. The profile pins are used to trigger and control the direction of the linear sweep for frequency, phase, and amplitude. All channels can be programmed separately for a linear sweep. In linear sweep mode, Profile Pin P0 is dedicated to Channel 0. Profile Pin P1 is dedicated to Channel 1, and so on.

The AD9958 has the ability to ramp up or ramp down (RU/RD) the output amplitude (using the 10-bit output scalar) before and after a linear sweep. If the RU/RD feature is desired, unused profile pins or unused SDIO_1/SDIO_2/SDIO_3 pins can be configured for the RU/RD operation.

To enable linear sweep mode for a particular channel, the AFP select bits (CFR[23:22]), the modulation level bits (FR1[9:8]), and the linear sweep enable bit (CFR[14]) are programmed.

The AFP select bits determine the type of linear sweep to be performed. The modulation level bits must be set to 00 (two-level) for that specific channel (see Table 19 and Table 20)

Table 19. Linear Sweep Parameter to Sweep

AFP Select (CFR[23:22])	Linear Sweep Enable (CFR[14])	Description
00	1	N/A
01	1	Amplitude sweep
10	1	Frequency sweep
11	1	Phase sweep

Table 20. Modulation Level Assignments

Modulation Level (FR1[9:8])	Description
00 (Required in Linear Sweep)	Two-level modulation
01	Four-level modulation
10	Eight-level modulation
11	16-level modulation

Setting the Slope of the Linear Sweep

The slope of the linear sweep is set by the intermediate step size (delta-tuning word) between S0 and E0 and the time spent (sweep ramp rate word) at each step. The resolution of the delta-tuning word is 32 bits for frequency, 14 bits for phase, and 10 bits for amplitude. The resolution for the delta ramp rate word is eight bits.

In linear sweep, each channel is assigned a rising delta word (RDW, Register 0x08) and a rising sweep ramp rate word (RSRR, Register 0x07). These settings apply when sweeping up toward E0. The falling delta word (FDW, Register 0x09) and falling sweep ramp rate (FSRR, Register 0x07) apply when sweeping down toward S0. Figure 36 displays a linear sweep up and then down using a profile pin. Note that the linear sweep no-dwell bit is disabled; otherwise, the sweep accumulator returns to 0 upon reaching E0.

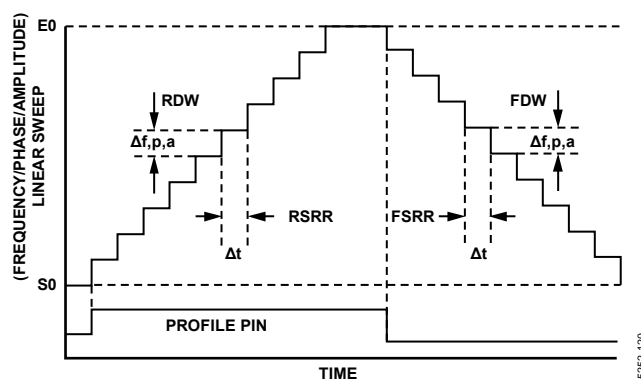

Figure 36. Linear Sweep Parameters

For a piecemeal or a nonlinear transition between S0 and E0, the delta-tuning words and ramp rate words can be reprogrammed during the transition to produce the desired response.

The formulas for calculating the step size of RDW or FDW for delta frequency, delta phase, or delta amplitude are as follows:

$$\Delta f = \left(\frac{RDW}{2^{32}} \right) \times SYSCLK \text{ (Hz)}$$

$$\Delta \Phi = \left(\frac{RDW}{2^{14}} \right) \times 360^\circ$$

$$\Delta a = \left(\frac{RDW}{2^{10}} \right) \times 1024 \text{ (DAC full-scale current)}$$

The formula for calculating delta time from RSRR or FSRR is

$$t = (RSRR) \times 1 / SYNC_CLK$$

At 500 MSPS operation (SYNC_CLK = 125 MHz), the maximum time interval between steps is $1/125 \text{ MHz} \times 256 = 2.048 \mu\text{s}$. The minimum time interval is $(1/125 \text{ MHz}) \times 1 = 8.0 \text{ ns}$.

The sweep ramp rate block (timer) consists of a loadable 8-bit down counter that continuously counts down from the loaded value to 1. When the ramp rate timer equals 1, the proper ramp rate value is loaded and the counter begins counting down to 1 again.

This load and countdown operation continues for as long as the timer is enabled. However, the count can be reloaded before reaching 1 by either of the following two methods:

- Method 1 is to change the profile pin. When the profile pin changes from Logic 0 to Logic 1, the rising sweep ramp rate (RSRR) register value is loaded into the ramp rate timer, which then proceeds to count down as normal. When the profile pin changes from Logic 1 to Logic 0, the falling sweep ramp rate (FSRR) register value is loaded into the ramp rate timer, which then proceeds to count down as normal.
- Method 2 is to set the CFR[14] bit and issue an I/O update. If sweep is enabled and CFR[14] is set, the ramp rate timer loads the value determined by the profile pin. If the profile pin is high, the ramp rate timer loads the RSRR; if the profile pin is low, the ramp rate timer loads FSRR.

Frequency Linear Sweep Example: AFP Bits = 10

In the following example, the modulation level bits (FR1[9:8]) = 00, the linear sweep enable bit (CFR[14]) = 1, and the linear sweep no-dwell bit (CFR[15]) = 0.

In linear sweep mode, when the profile pin transitions from low to high, the RDW is applied to the input of the sweep accumulator and the RSRR register is loaded into the sweep rate timer.

The RDW accumulates at the rate given by the rising sweep ramp rate (RSRR) bits until the output is equal to the CW1 register value. The sweep is then complete, and the output is held constant in frequency.

When the profile pin transitions from high to low, the FDW is applied to the input of the sweep accumulator and the FSRR bits are loaded into the sweep rate timer.

The FDW accumulates at the rate given by the falling sweep ramp rate (FSRR) until the output is equal to the CFTW0 register (Register 0x04) value. The sweep is then complete, and the output is held constant in frequency.

See Figure 37 for the linear sweep block diagram. Figure 39 depicts a frequency sweep with no-dwell mode disabled. In this mode, the output follows the state of the profile pin. A phase or amplitude sweep works in the same manner.

LINEAR SWEEP NO-DWELL MODE

If the linear sweep no-dwell bit is set (CFR[15]), the rising sweep is started in an identical manner to the dwell linear sweep mode; that is, upon detecting Logic 1 on the profile input pin, the rising sweep action is initiated. The word continues to sweep up at the rate set by the rising sweep ramp rate at the resolution set by the rising delta word until it reaches the terminal value. Upon reaching the terminal value, the output immediately reverts to the starting point and remains until Logic 1 is detected on the profile pin.

Figure 38 shows an example of the no-dwell mode. The points labeled A indicate where a rising edge is detected on the profile pin, and the points labeled B indicate where the AD9958 has determined that the output has reached E0 and reverts to S0. The falling sweep ramp rate bits (LSRR[15:8]) and the falling delta word bits (FDW[31:0]) are unused in this mode.

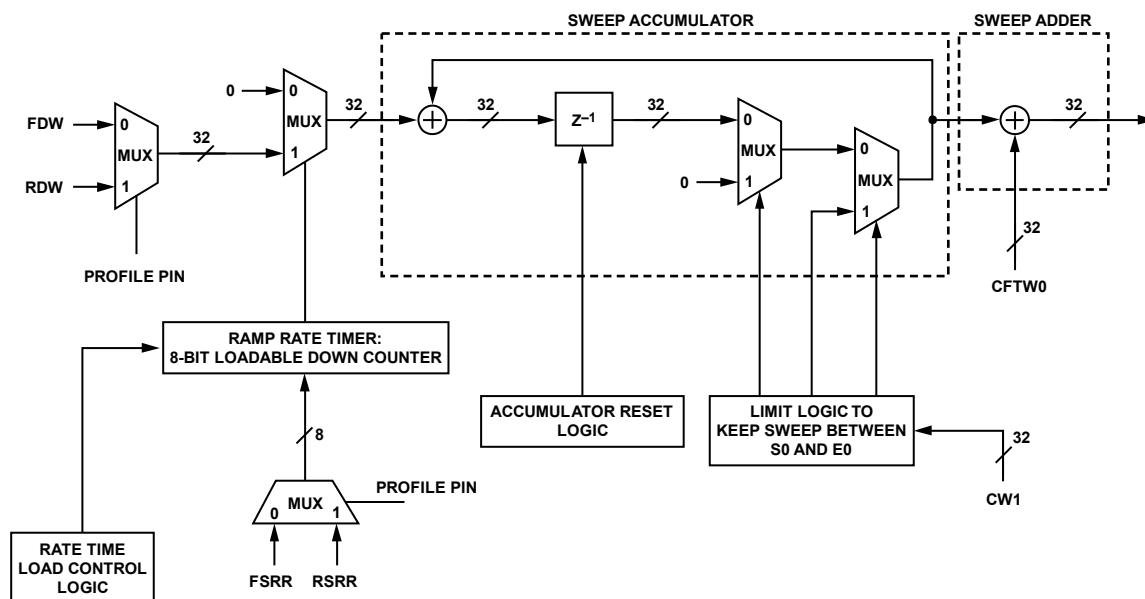
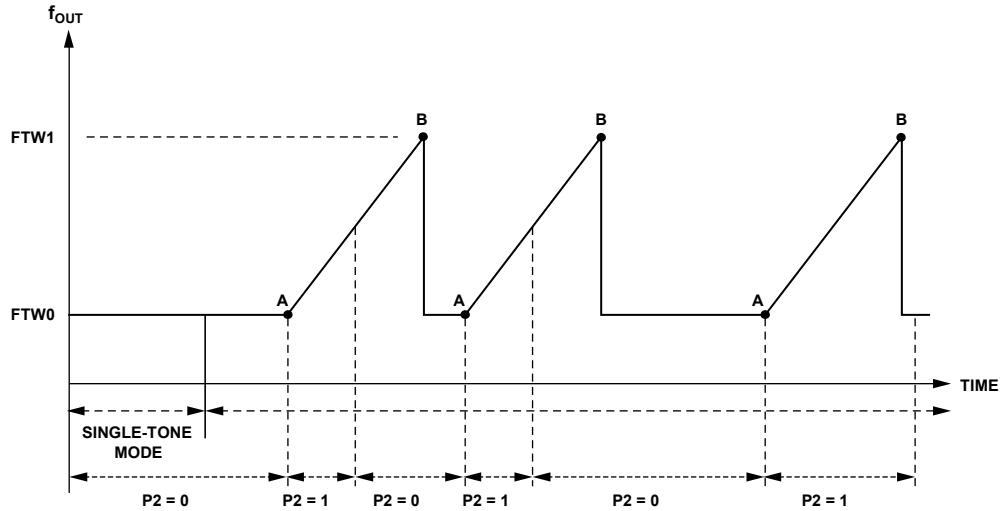

Figure 37. Linear Sweep Block Diagram

05252-121



LINEAR SWEEP MODE ENABLE—NO-DWELL BIT SET
 Figure 38. Linear Sweep Mode (No-Dwell Enabled)

05252-147

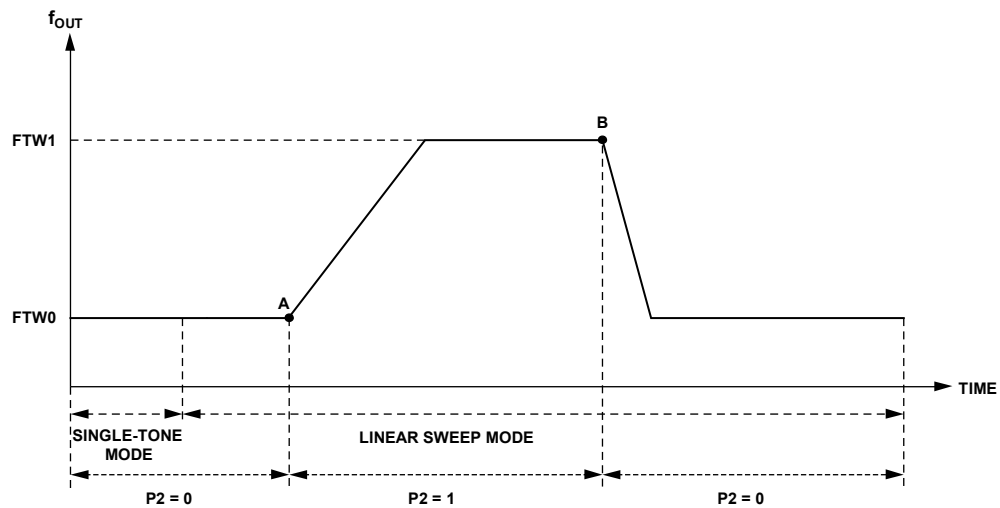

AT POINT A: LOAD RISING RAMP RATE REGISTER, APPLY RDW<31:0>
 AT POINT B: LOAD FALLING RAMP RATE REGISTER, APPLY FDW<31:0>
 Figure 39. Linear Sweep Mode (No-Dwell Disabled)

05252-148

SWEEP AND PHASE ACCUMULATOR CLEARING FUNCTIONS

The AD9958 allows two different clearing functions. The first is a continuous zeroing of the sweep logic and phase accumulator (clear and hold). The second is a clear and release or automatic zeroing function. CFR[4] is the autoclear sweep accumulator bit and CFR[2] is the autoclear phase accumulator bit. The continuous clear bits are located in CFR, where CFR[3] clears the sweep accumulator and CFR[1] clears the phase accumulator.

Continuous Clear Bits

The continuous clear bits are static control signals that, when active high, hold the respective accumulator at 0 while the bit is active. When the bit goes low, the respective accumulator is allowed to operate.

Clear and Release Bits

The autoclear sweep accumulator bit, when set, clears and releases the sweep accumulator upon an I/O update or a change in the profile input pins. The autoclear phase accumulator bit, when set, clears and releases the phase accumulator upon an I/O update or a change in the profile pins. The automatic clearing function is repeated for every subsequent I/O update or change in profile pins until the clear and release bits are reset via the serial port.

OUTPUT AMPLITUDE CONTROL MODE

The 10-bit scale factor (multiplier) controls the ramp-up and ramp-down (RU/RD) time of an on/off emission from the DAC. In burst transmissions of digital data, it reduces the adverse spectral impact of abrupt bursts of data. The multiplier can be bypassed by clearing the amplitude multiplier enable bit (ACR[12] = 0).

Automatic and manual RU/RD modes are supported. The automatic mode generates a zero-scale up to a full-scale (10 bits) linear ramp at a rate determined by ACR (Register 0x06). The start and direction of the ramp can be controlled by either the profile pins or the SDIO_1/SDIO_2/SDIO_3 pins.

Manual mode allows the user to directly control the output amplitude by manually writing to the amplitude scale factor value in the ACR (Register 0x06). Manual mode is enabled by setting ACR[12] = 1 and ACR[11] = 0.

Automatic RU/RD Mode Operation

Automatic RU/RD mode is active when both ACR[12] and ACR[11] are set. When automatic RU/RD is enabled, the scale factor is internally generated and applied to the multiplier input port for scaling the output. The scale factor is the output of a 10-bit counter that increments/decrements at a rate set by the 8-bit output ramp rate register. The scale factor increments if the external pin is high and decrements if the pin is low. The internally generated scale factor step size is controlled by ACR[15:14]. Table 21 describes the increment/decrement step size of the internally generated scale factor per ACR[15:14].

Table 21. Increment/Decrement Step Size Assignments

Increment/Decrement Step Size (ACR [15:14])	Size
00	1
01	2
10	4
11	8

Table 23. Channel Assignments of SDIO_1/SDIO_2/SDIO_3 Pins for RU/RD Operation

Linear Sweep and RU/RD Modes Enabled Simultaneously	SDIO_1	SDIO_2	SDIO_3	Ramp-Up/Ramp-Down Control Signal Assignment
Enable for CH0	1	0	0	Ramp-up function for CH0
Enable for CH0	1	0	1	Ramp-down function for CH0
Enable for CH1	1	1	0	Ramp-up function for CH1
Enable for CH1	1	1	1	Ramp-down function for CH1

A special feature of this mode is that the maximum output amplitude allowed is limited by the contents of the amplitude scale factor (ACR[9:0]). This allows the user to ramp to a value less than full scale.

Ramp Rate Timer

The ramp rate timer is a loadable down counter that generates the clock signal to the 10-bit counter that generates the internal scale factor. The ramp rate timer is loaded with the value of the LSRR (Register 0x07) each time the counter reaches 1 (decimal). This load and countdown operation continues for as long as the timer is enabled unless the timer is forced to load before reaching a count of 1.

If the load ARR at I/O_UPDATE bit (ACR[10]) is set, the ramp rate timer is loaded at an I/O update, a change in profile input, or upon reaching a value of 1. The ramp timer can be loaded before reaching a count of 1 by three methods.

- In the first method, the profile pins or the SDIO_1/SDIO_2/SDIO_3 pins are changed. When the control signal changes state, the ACR value is loaded into the ramp rate timer, which then proceeds to count down as normal.
- In the second method, the load ARR at I/O_UPDATE bit (ACR[10]) is set, and an I/O update is issued.
- The third method is to change from inactive automatic RU/RD mode to active automatic RU/RD mode.

RU/RD Pin-to-Channel Assignment

When all four channels are in single-tone mode, the profile pins are used for RU/RD operation.

When linear sweep and RU/RD are activated, the SDIO_1/SDIO_2/SDIO_3 pins are used for RU/RD operation.

In modulation mode, refer to the Modulation Mode section for pin assignments.

Table 22. Profile Pin Assignments for RU/RD Operation

Profile Pin	RU/RD Operation
P2	CH0
P3	CH1

SYNCHRONIZING MULTIPLE AD9958 DEVICES

The AD9958 allows easy synchronization of multiple AD9958 devices. At power-up, the phase of SYNC_CLK can be offset between multiple devices. To correct for the offset and align the SYNC_CLK edges, there are three methods (one automatic mode and two manual modes) of synchronizing the SYNC_CLK edges. These modes force the internal state machines of multiple devices to a known state, which aligns the SYNC_CLK edges.

In addition, the user must send a coincident I/O_UPDATE to multiple devices to maintain synchronization. Any mismatch in REF_CLK phase between devices results in a corresponding phase mismatch on the SYNC_CLK edges.

AUTOMATIC MODE SYNCHRONIZATION

In automatic mode, multiple part synchronization is achieved by connecting the SYNC_OUT pin on the master device to the SYNC_IN pins of the slave devices. Devices are configured as master or slave through programming bits, accessible via the serial port.

A configuration for synchronizing multiple AD9958 devices in automatic mode is shown in the Application Circuits section. In this configuration, the AD9510 provides coincident REF_CLK and SYNC_OUT signals to all devices.

Operation

The first step is to program the master and slave devices for their respective roles and then write the auto sync enable bit (FR2[7] = 1. Enabling the master device is performed by writing its multidevice sync master enable bit in Function Register 2 (FR2[6]) = 1. This causes the SYNC_OUT of the master device to output a pulse that has a pulse width equal to one system clock period and a frequency equal to one-fourth of the system clock frequency. Enabling devices as slaves is performed by writing FR2[6] = 0.

In automatic synchronizing mode, the slave devices sample SYNC_OUT pulses from the master device on the SYNC_IN of the slave devices, and a comparison of all state machines is made by the autosynchronization circuitry. If the slave devices state machines are not identical to the master, the slave devices state machines are stalled for one system clock cycle. This procedure synchronizes the slave devices within three SYNC_CLK periods.

Delay Time Between SYNC_OUT and SYNC_IN

When the delay between SYNC_OUT and SYNC_IN exceeds one system clock period, the system clock offset bits (FR2[1:0]) are used to compensate. The default state of these bits is 00, which implies that the SYNC_OUT of the master and the SYNC_IN of the slave have a propagation delay of less than one system clock period. If the propagation time is greater than one system clock period, the time should be measured and the appropriate offset programmed. Table 24 describes the delays required per system clock offset value.

Table 24. System Clock Offset (Delay) Assignments

System Clock Offset (FR2[1:0])	SYNC_OUT/SYNC_IN Propagation Delay
00	$0 \leq \text{delay} \leq 1$
01	$1 \leq \text{delay} \leq 2$
10	$2 \leq \text{delay} \leq 3$
11	$3 \leq \text{delay} \leq 4$

Automatic Synchronization Status Bits

If a slave device falls out of sync, the sync status bit is set high. The multidevice sync status bit (FR2[5]) can be read through the serial port. It is automatically cleared when read.

The synchronization routine continues to operate regardless of the state of FR2[5]. FR2[5] can be masked by writing Logic 1 to the multidevice sync mask bit (FR2[4]). If FR2[5] is masked, it is held low.

MANUAL SOFTWARE MODE SYNCHRONIZATION

Manual software mode is enabled by setting the manual software sync bit (FR1[0]) to Logic 1 in a device. In this mode, the I/O update that writes the manual software sync bit to Logic 0 stalls the state machine of the clock generator for one system clock cycle. Stalling the clock generation state machine by one cycle changes the phase relationship of SYNC_CLK between devices by one system clock period (90°).

Note that the user may have to repeat this process until the devices have their SYNC_CLK signals in phase. The SYNC_IN input can be left floating because it has an internal pull-up. The SYNC_OUT pin is not used.

The synchronization is complete when the master and slave devices have their SYNC_CLK signals in phase.

MANUAL HARDWARE MODE SYNCHRONIZATION

Manual hardware mode is enabled by setting the manual hardware sync bit (FR1[1]) to Logic 1 in a device. In manual hardware synchronization mode, the SYNC_CLK stalls by one system clock cycle each time a rising edge is detected on the SYNC_IN input. Stalling the SYNC_CLK state machine by one cycle changes the phase relationship of SYNC_CLK between devices by one system clock period (90°).

Note that the user may have to repeat the process until the devices have their SYNC_CLK signals in phase. The SYNC_IN input can be left floating because it has an internal pull-up. The SYNC_OUT is not used.

The synchronization is complete when the master and slave devices have their SYNC_CLK signals in phase.

I/O_UPDATE, SYNC_CLK, AND SYSTEM CLOCK RELATIONSHIPS

I/O_UPDATE and SYNC_CLK are used together to transfer data from the serial I/O buffer to the active registers in the device. Data in the buffer is inactive.

SYNC_CLK is a rising edge active signal. It is derived from the system clock and a divide-by-4 frequency divider. The SYNC_CLK, which is externally provided, can be used to synchronize external hardware to the AD9958 internal clocks.

I/O_UPDATE initiates the start of a buffer transfer. It can be sent synchronously or asynchronously relative to the SYNC_CLK.

If the setup time between these signals is met, then constant latency (pipeline) to the DAC output exists. For example, if repetitive changes to phase offset via the SPI port is desired, the latency of those changes to the DAC output is constant; otherwise, a time uncertainty of one SYNC_CLK period is present.

The I/O_UPDATE is essentially oversampled by the SYNC_CLK. Therefore, I/O_UPDATE must have a minimum pulse width greater than one SYNC_CLK period.

The timing diagram shown in Figure 40 depicts when data in the buffer is transferred to the active registers.

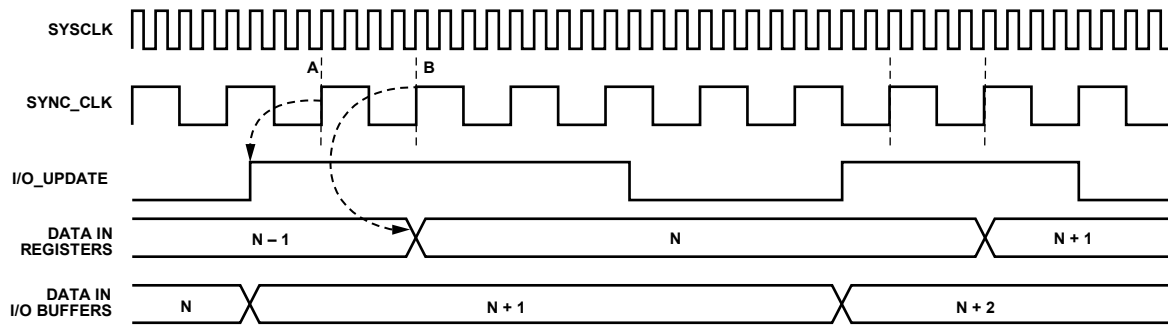

THE DEVICE REGISTERS AN I/O UPDATE AT POINT A. THE DATA IS TRANSFERRED FROM THE ASYNCHRONOUSLY LOADED I/O BUFFERS AT POINT B.

Figure 40. I/O_UPDATE Transferring Data from I/O Buffer to Active Registers

05252-149

SERIAL I/O PORT

OVERVIEW

The AD9958 serial I/O port offers multiple configurations to provide significant flexibility. The serial I/O port offers an SPI-compatible mode of operation that is virtually identical to the SPI operation found in earlier Analog Devices DDS products. The flexibility is provided by four data pins (SDIO_0, SDIO_1, SDIO_2, SDIO_3) that allow four programmable modes of serial I/O operation.

Three of the four data pins (SDIO_1, SDIO_2, SDIO_3) can be used for functions other than serial I/O port operation. These pins can also be used to initiate a ramp-up or ramp-down (RU/RD) of the 10-bit amplitude output scalar. In addition, SDIO_3 can be used to provide the SYNC_I/O function that resynchronizes the serial I/O port controller if it is out of proper sequence.

The maximum speed of the serial I/O port SCLK is 200 MHz, but the four data pins (SDIO_0, SDIO_1, SDIO_2, SDIO_3) can be used to further increase data throughput. The maximum data throughput using all the SDIO pins (SDIO_0, SDIO_1, SDIO_2, SDIO_3) is 800 Mbps.

Note that both channels share Register 0x03 to Register 0x18, which are shown in the Register Maps and Bit Descriptions section. This address sharing enables both DDS channels to be written to simultaneously. For example, if a common frequency tuning word is desired for both channels, it can be written once through the serial I/O port to both channels. This is the default mode of operation (all channels enabled). To enable each channel to be independent, the two channel enable bits found in the channel select register (CSR, Register 0x00) must be used.

There are effectively four sets or copies of addresses (Register 0x03 to Register 0x18) that the channel enable bits can access to provide channel independence. See the Descriptions for Control Registers section for further details of programming channels that are common to or independent from each other. To properly read back Register 0x03 to Register 0x18, the user must enable only one channel enable bit at a time.

Serial operation of the AD9958 occurs at the register level, not the byte level; that is, the controller expects that all bytes contained in the register address are accessed. The SYNC_I/O function can be used to abort an I/O operation, thereby allowing fewer than all bytes to be accessed. This feature can be used to program only a part of the addressed register. Note that only completed bytes are affected.

There are two phases to a serial communications cycle. Phase 1 is the instruction cycle, which writes the instruction byte into the AD9958. Each bit of the instruction byte is registered on each corresponding rising edge of SCLK. The instruction byte defines whether the upcoming data transfer is a write or read operation. The instruction byte contains the serial address of the address register.

Phase 2 of the I/O cycle consists of the actual data transfer (write/read) between the serial port controller and the serial port buffer. The number of bytes transferred during this phase of the communication cycle is a function of the register being accessed. The actual number of additional SCLK rising edges required for the data transfer and instruction byte depends on the number of bytes in the register and the serial I/O mode of operation.

For example, when accessing Function Register 1 (FR1), which is three bytes wide, Phase 2 of the I/O cycle requires that three bytes be transferred. After transferring all data bytes per the instruction byte, the communication cycle is completed for that register.

At the completion of a communication cycle, the AD9958 serial port controller expects the next set of rising SCLK edges to be the instruction byte for the next communication cycle. All data written to the AD9958 is registered on the rising edge of SCLK. Data is read on the falling edge of SCLK (see Figure 43 through Figure 49). The timing specifications for Figure 41 and Figure 42 are described in Table 25.

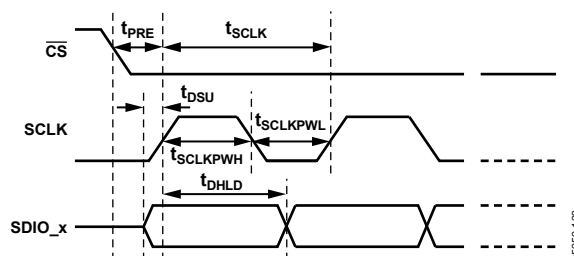

Figure 41. Setup and Hold Timing for the Serial I/O Port

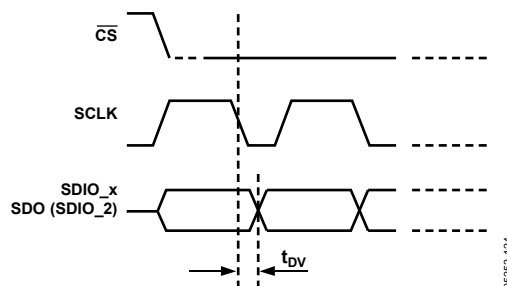

Figure 42. Timing Diagram for Data Read for Serial I/O Port

Table 25. Timing Specifications

Parameter	Min	Unit	Description
t _{PRE}	1.0	ns min	CS setup time
t _{SCLK}	5.0	ns min	Period of serial data clock
t _{DSU}	2.2	ns min	Serial data setup time
t _{SCLKPWH}	2.2	ns min	Serial data clock pulse width high
t _{SCLKPWL}	1.6	ns min	Serial data clock pulse width low
t _{DHL}	0	ns min	Serial data hold time
t _{DV}	12	ns min	Data valid time

AD9958

Each set of communication cycles does not require an I/O update to be issued. The I/O update transfers data from the I/O port buffer to active registers. The I/O update can be sent for each communication cycle or can be sent when all serial operations are complete. However, data is not active until an I/O update is sent, with the exception of the channel enable bits in the channel select register (CSR). These bits do not require an I/O update to be enabled.

INSTRUCTION BYTE DESCRIPTION

The instruction byte contains the following information:

MSB			LSB				
D7	D6	D5	D4	D3	D2	D1	D0
R/ \overline{W}	x ¹	x ¹	A4	A3	A2	A1	A0

¹x = don't care bit.

Bit D7 of the instruction byte (R/ \overline{W}) determines whether a read or write data transfer occurs after the instruction byte write. A logic high indicates a read operation. A logic low indicates a write operation.

Bit D4 to Bit D0 of the instruction byte determine which register is accessed during the data transfer portion of the communication cycle. The internal byte addresses are generated by the AD9958.

SERIAL I/O PORT PIN DESCRIPTION

Serial Data Clock (SCLK)

The serial data clock pin is used to synchronize data to and from the internal state machines of the AD9958. The maximum SCLK toggle frequency is 200 MHz.

Chip Select (\overline{CS})

The chip select pin allows more than one AD9958 device to be on the same set of serial communications lines. The chip select is an active low enable pin. SDIO_x inputs go to a high impedance state when \overline{CS} is high. If \overline{CS} is driven high during any communication cycle, that cycle is suspended until \overline{CS} is reactivated low. The \overline{CS} pin can be tied low in systems that maintain control of SCLK.

Serial Data I/O (SDIO_x)

Of the four SDIO pins, only the SDIO_0 pin is a dedicated SDIO pin. SDIO_1, SDIO_2, and SDIO_3 can also be used to ramp up/ramp down the output amplitude. Bits[2:1] in the channel select register (CSR, Register 0x00) control the configuration of these pins. See the Serial I/O Modes of Operation for more information.

SERIAL I/O PORT FUNCTION DESCRIPTION

Serial Data Out (SDO)

The SDO function is available in single-bit (3-wire) mode only. In SDO mode, data is read from the SDIO_2 pin for protocols that use separate lines for transmitting and receiving data (see Table 26 for pin configuration options). Bits[2:1] in the channel select register (CSR, Register 0x00) control the configuration of

this pin. The SDO function is not available in 2-bit or 4-bit serial I/O modes.

SYNC_I/O

The SYNC_I/O function is available in 1-bit and 2-bit modes. SDIO_3 serves as the SYNC_I/O pin when this function is active. Bits CSR[2:1] control the configuration of this pin. Otherwise, the SYNC_I/O function is used to synchronize the I/O port state machines without affecting the addressable register contents. An active high input on the SYNC_I/O (SDIO_3) pin causes the current communication cycle to abort. After SDIO_3 returns low (Logic 0), another communication cycle can begin, starting with the instruction byte write. The SYNC_I/O function is not available in 4-bit serial I/O mode.

MSB/LSB TRANSFER DESCRIPTION

The AD9958 serial port can support both most significant bit (MSB) first or least significant bit (LSB) first data formats. This functionality is controlled by CSR[0]. MSB first is the default mode. When CSR[0] is set high, the AD9958 serial port is in LSB first format. The instruction byte must be written in the format indicated by CSR[0], that is, if the AD9958 is in LSB first mode, the instruction byte must be written from LSB to MSB. If the AD9958 is in MSB first mode (default), the instruction byte must be written from MSB to LSB.

Example Operation

To write Function Register 1 (FR1, Register 0x01) in MSB first format, apply an instruction byte of 00000001 starting with the MSB (in the following example instruction byte, the MSB is D7). From this instruction, the internal controller recognizes a write transfer of three bytes starting with the MSB, FR1[23]. Bytes are written on each consecutive rising SCLK edge until Bit 0 is transferred. When the last data bit is written, the I/O communication cycle is complete and the next byte is considered an instruction byte.

Example Instruction Byte¹

MSB							LSB
D7	D6	D5	D4	D3	D2	D1	D0
0	0	0	0	0	0	0	1

¹Note that the bit values are for example purposes only.

To write Function Register 1 (FR1) in LSB first format, apply an instruction byte of 00000001, starting with the LSB bit (in the preceding example instruction byte, the LSB is D0). From this instruction, the internal controller recognizes a write transfer of three bytes, starting with the LSB, FR1[0]. Bytes are written on each consecutive rising SCLK edge until Bit 23 is transferred. When the last data bit is written, the I/O communication cycle is complete and the next byte is considered an instruction byte.

SERIAL I/O MODES OF OPERATION

The following are the four programmable modes of serial I/O port operation:

- Single-bit serial 2-wire mode (default mode)
- Single-bit serial 3-wire mode
- 2-bit serial mode
- 4-bit serial mode (SYNC_I/O not available)

Table 26 displays the function of all six serial I/O interface pins, depending on the mode of serial I/O operation programmed.

Table 26. Serial I/O Port Pin Function vs. Serial I/O Mode

Pin	Single-Bit Serial 2-Wire Mode	Single-Bit Serial 3-Wire Mode	2-Bit Serial Mode	4-Bit Serial Mode
SCLK	Serial clock	Serial clock	Serial clock	Serial clock
$\overline{\text{CS}}$	Chip select	Chip select	Chip select	Chip select
SDIO_0	Serial data I/O	Serial data in	Serial data I/O	Serial data I/O
SDIO_1	Not used for SDIO ¹	Not used for SDIO ¹	Serial data I/O	Serial data I/O
SDIO_2	Not used for SDIO ¹	Serial data out (SDO)	Not used for SDIO ¹	Serial data I/O
SDIO_3	SYNC_I/O	SYNC_I/O	SYNC_I/O	Serial data I/O

¹In serial mode, these pins (SDIO_0/SDIO_1/SDIO_2/SDIO_3) can be used for RU/RD operation.

The two bits in the channel select register, CSR[2:1], set the serial I/O mode of operation and are defined in Table 27.

Table 27. Serial I/O Mode of Operation

Serial I/O Mode Select (CSR[2:1])	Mode of Operation
00	Single-bit serial mode (2-wire mode)
01	Single-bit serial mode (3-wire mode)
10	2-bit serial mode
11	4-bit serial mode

Single-Bit Serial (2-Wire and 3-Wire) Modes

The single-bit serial mode interface allows read/write access to all registers that configure the AD9958. MSB first or LSB first transfer formats are supported. In addition, the single-bit serial mode interface port can be configured either as a single pin I/O, which allows a 2-wire interface, or as two unidirectional pins for input/output, which enable a 3-wire interface. Single-bit mode allows the use of the SYNC_I/O function.

In single-bit serial mode, 2-wire interface operation, the SDIO_0 pin is the single serial data I/O pin. In single-bit serial mode 3-wire interface operation, the SDIO_0 pin is the serial data input pin and the SDIO_2 pin is the output data pin. Regardless of the number of wires used in the interface, the SDIO_3 pin is configured as an input and operates as the SYNC_I/O pin in the single-bit serial mode and 2-bit serial mode. The SDIO_1 pin is unused in this mode (see Table 26).

2-Bit Serial Mode

The SPI port operation in 2-bit serial mode is identical to the SPI port operation in single-bit serial mode, except that two bits of data are registered on each rising edge of SCLK. Therefore, it only takes four clock cycles to transfer eight bits of information. The SDIO_0 pin contains the even numbered data bits using the notation D[7:0], and the SDIO_1 pin contains the odd numbered data bits. This even and odd numbered pin/data alignment is valid in both MSB and LSB first formats (see Figure 44).

4-Bit Serial Mode

The SPI port in 4-bit serial mode is identical to the SPI port in single-bit serial mode, except that four bits of data are registered on each rising edge of SCLK. Therefore, it takes only two clock cycles to transfer eight bits of information. The SDIO_0 and SDIO_2 pins contain even numbered data bits using the notation D[7:0], and the SDIO_1 pin contains the LSB of the nibble. The SDIO_1 and SDIO_3 pins contain the odd numbered data bits, and the SDIO_1 pin contains the LSB of the nibble to be accessed.

Note that when programming the device for 4-bit serial mode, it is important to keep the SDIO_3 pin at Logic 0 until the device is programmed out of the single-bit serial mode. Failure to do so can result in the serial I/O port controller being out of sequence.

Figure 43 through Figure 45 represent write timing diagrams for each of the serial I/O modes available. Both MSB and LSB first modes are shown. LSB first bits are shown in parentheses. The clock stall low/high feature shown is not required. It is used to show that data (SDIO) must have the proper setup time relative to the rising edge of SCLK.

Figure 46 through Figure 49 represent read timing diagrams for each of the serial I/O modes available. Both MSB and LSB first modes are shown. LSB first bits are shown in parentheses. The clock stall low/high feature shown is not required. It is used to show that data (SDIO) must have the proper setup time relative to the rising edge of SCLK for the instruction byte and the read data that follows the falling edge of SCLK.

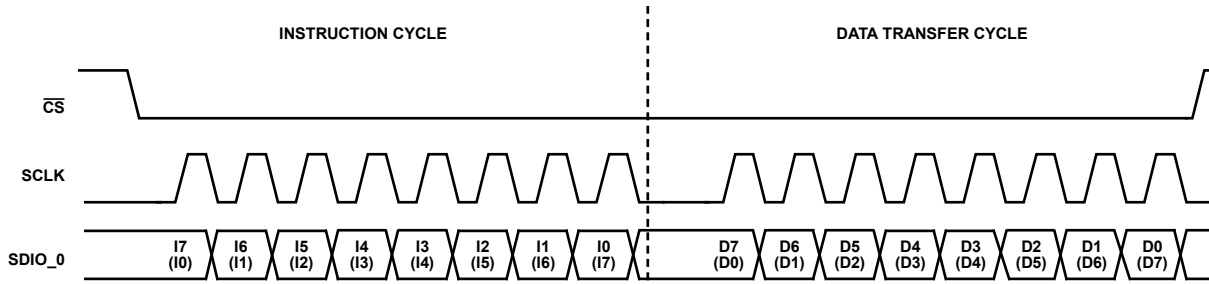

Figure 43. Single-Bit Serial Mode Write Timing—Clock Stall Low

05252-125

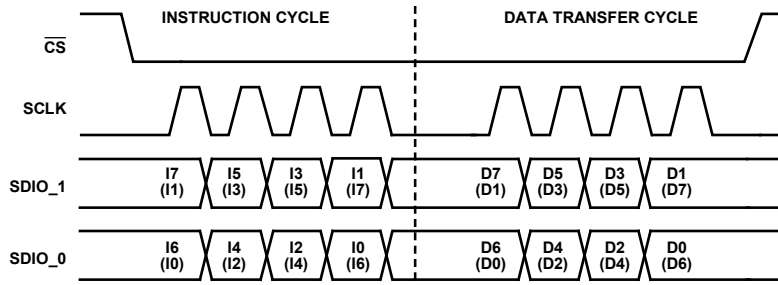

Figure 44. 2-Bit Serial Mode Write Timing—Clock Stall Low

05252-126

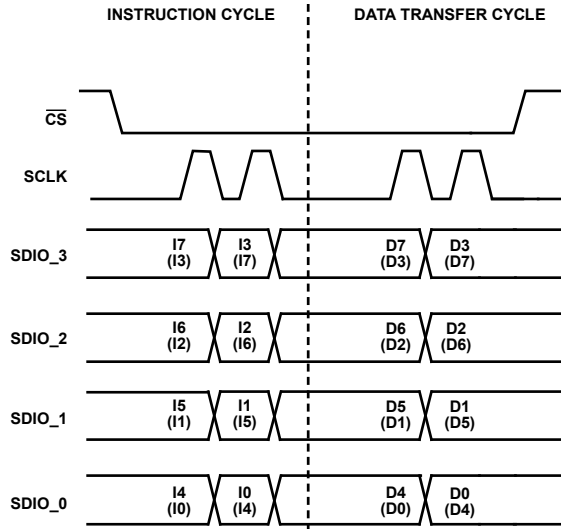

Figure 45. 4-Bit Serial Mode Write Timing—Clock Stall Low

05252-127

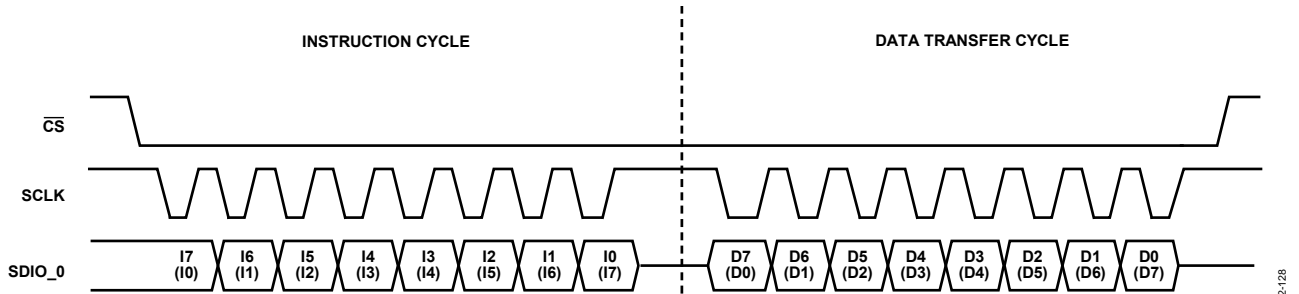

Figure 46. Single-Bit Serial Mode (2-Wire) Read Timing—Clock Stall High

06252-128

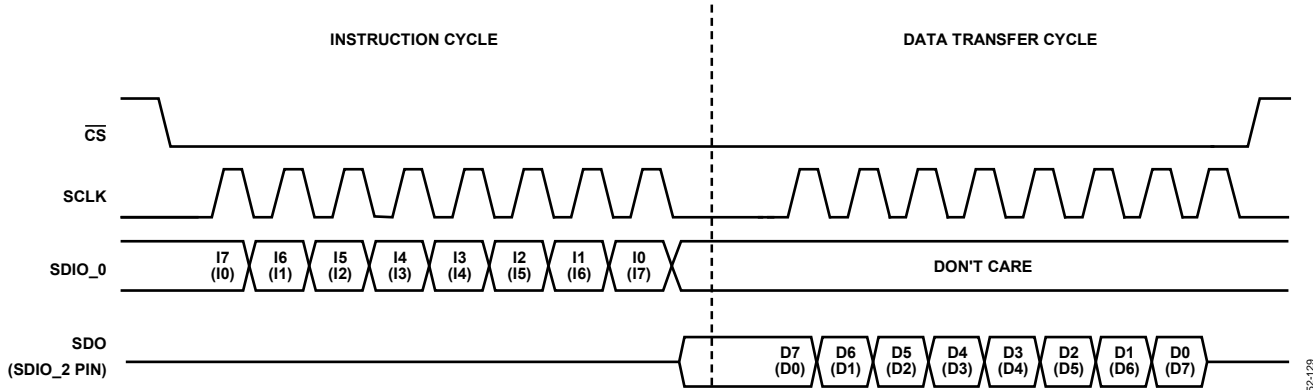

Figure 47. Single-Bit Serial Mode (3-Wire) Read Timing—Clock Stall Low

06252-129

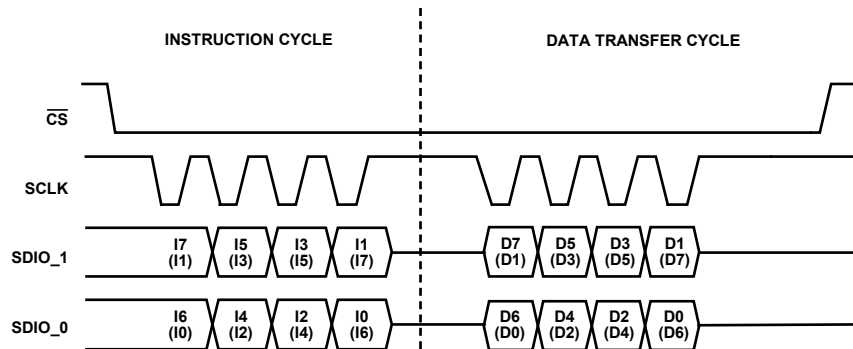

Figure 48. 2-Bit Serial Mode Read Timing—Clock Stall High

06252-130

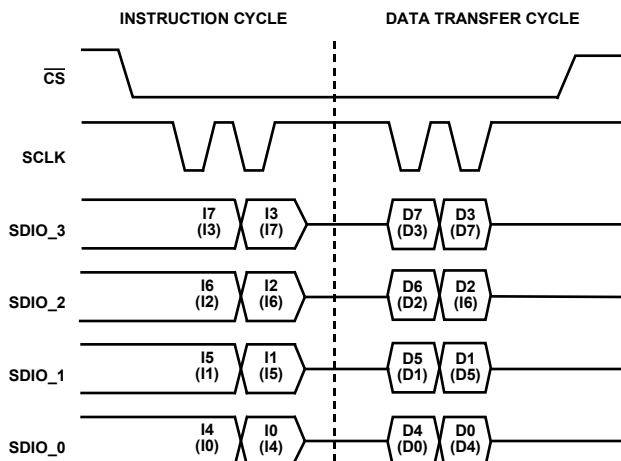

Figure 49. 4-Bit Serial Mode Read Timing—Clock Stall High

06252-131

REGISTER MAPS AND BIT DESCRIPTIONS

REGISTER MAPS

Table 28. Control Register Map

Register Name (Serial Address)	Bit Range	Bit 7 (MSB)	Bit 6	Bit 5	Bit 4	Bit 3	Bit 2	Bit 1	Bit 0 (LSB)	Default Value
Channel Select Register (CSR) (0x00)	[7:0]	Channel 1 enable ¹	Channel 0 enable ¹	Open ²	Open ²	Must be 0	Serial I/O mode select[2:1]		LSB first	0xF0
Function Register 1 (FR1) (0x01)	[23:16]	VCO gain control	PLL divider ratio[22:18]				Charge pump control[17:16]			0x00
	[15:8]	Open	Profile pin configuration (PPC)[14:12]			Ramp-up/ramp-down (RU/RD)[11:10]	Modulation level[9:8]			0x00
	[7:0]	Reference clock input power-down	External power-down mode	SYNC_CLK disable	DAC reference power-down	Open[3:2]	Manual hardware sync	Manual software sync		0x00
Function Register 2 (FR2) (0x02)	[15:8]	All channels autoclear sweep accumulator	All channels clear wweep accumulator	All channels autoclear phase accumulator	All channels clear phase accumulator	Open[11:8]				0x00
	[7:0]	Auto sync enable	Multidevice sync master enable	Multidevice sync status	Multidevice sync mask	Open[3:2]	System clock offset[1:0]			0x00

¹ Channel enable bits do not require an I/O update to be activated. These bits are active immediately after the byte containing the bits is written. All other bits need an I/O update to become active. The two channel enable bits shown in Table 28 are used to enable/disable any combination of the two channels. The default for both channels is enabled. In readback mode, enable one channel enable bit at a time.

² This bit must be disabled (Logic 0) in readback mode.

In the channel select register, if the user wants two different frequencies for the two DDS channels, use the following protocol:

1. Enable (Logic 1) the Channel 0 enable bit, which is located in the channel select register, and disable the Channel 1 enable bit (Logic 0).
2. Write the desired frequency tuning word for Channel 0, as described in Step 1, and then disable the Channel 0 enable bit (Logic 0).
3. Enable the Channel 1 enable bit only, located in the channel select Register.
4. Write the desired frequency tuning word for Channel 1 in Step 3.

Table 29. Channel Register Map

Register Name (Serial Address)	Bit Range	Bit 7 (MSB)	Bit 6	Bit 5	Bit 4	Bit 3	Bit 2	Bit 1	Bit 0 (LSB)	Default Value	
Channel Function Register ¹ (CFR) (0x03)	[23:16]	Amplitude freq. phase (AFP) select[23:22]		Open[21:16]							0x00
	[15:8]	Linear sweep no-dwell	Linear sweep enable	Load SRR at I/O_UPDATE	Open[12:11]		Must be 0	DAC full-scale current control[9:8]		0x03	
	[7:0]	Digital power-down	DAC power-down	Matched pipe delays active	Autoclear sweep accumulator	Clear sweep accumulator	Autoclear phase accumulator	Clear phase accumulator ²	Sine wave output enable	0x02	
Channel Frequency Tuning Word 0 ¹ (CFTW0) (0x04)	[31:24]	Frequency Tuning Word 0[31:24]									0x00
	[23:16]	Frequency Tuning Word 0[23:16]									N/A
	[15:8]	Frequency Tuning Word 0[15:8]									N/A
	[7:0]	Frequency Tuning Word 0[7:0]									N/A
Channel Phase Offset Word 0 ¹ (CPOW0) (0x05)	[15:8]	Open[15:14]		Phase Offset Word 0[13:8]							0x00
	[7:0]	Phase Offset Word 0[7:0]									0x00
Amplitude Control Register (ACR) (0x06)	[23:16]	Amplitude Ramp Rate[23:16]									N/A
	[15:8]	Increment/decrement step size[15:14]	Open	Amplitude multiplier enable	Ramp-up/ramp-down enable	Load ARR at I/O_UPDATE	Amplitude scale factor[9:8]				0x00
	[7:0]	Amplitude scale factor[7:0]									0x00
Linear Sweep Ramp Rate ¹ (LSRR) (0x07)	[15:8]	Falling sweep ramp rate (FSRR)[15:8]									N/A
	[7:0]	Rising sweep ramp rate (RSRR)[7:0]									N/A
LSR Rising Delta Word ¹ (RDW) (0x08)	[31:24]	Rising delta word[31:24]									N/A
	[23:16]	Rising delta word[23:16]									N/A
	[15:8]	Rising delta word[15:8]									N/A
	[7:0]	Rising delta word[7:0]									N/A
LSR Falling Delta Word ¹ (FDW) (0x09)	[31:24]	Falling delta word[31:24]									N/A
	[23:16]	Falling delta word[23:16]									N/A
	[15:8]	Falling delta word[15:8]									N/A
	[7:0]	Falling delta word[7:0]									N/A

¹ There are two sets of channel registers and profile registers, one per channel. This is not shown in the Table 29 or Table 30 because the addresses of all channel registers and profile registers are the same for each channel. Therefore, the channel enable bits (CSR[7:6]) determine if the channel registers and/or profile registers of each channel are written to or not.

² The clear phase accumulator bit (CFR[1]) is set to Logic 1 after a master reset. It self-clears or is set to Logic 0 when an I/O update is asserted.

AD9958

Table 30. Profile Register Map¹

Register Name (Address)	Bit Range	Bit 7 (MSB)	Bit 6	Bit 5	Bit 4	Bit 3	Bit 2	Bit 1	Bit 0 (LSB)	Default Value
Channel Word 1 (CW1) (0x0A)	[31:0]	Frequency tuning word[31:0] or phase word[31:18] or amplitude word[31:22]								N/A
Channel Word 2 (CW2) (0x0B)	[31:0]	Frequency tuning word[31:0] or phase word[31:18] or amplitude word[31:22]								N/A
Channel Word 3 (CW3) (0x0C)	[31:0]	Frequency tuning word[31:0] or phase word[31:18] or amplitude word[31:22]								N/A
Channel Word 3 (CW4) (0x0D)	[31:0]	Frequency tuning word[31:0] or phase word[31:18] or amplitude word[31:22]								N/A
Channel Word 5 (CW5) (0x0E)	[31:0]	Frequency tuning word[31:0] or phase word[31:18] or amplitude word[31:22]								N/A
Channel Word 6 (CW6) (0x0F)	[31:0]	Frequency tuning word[31:0] or phase word[31:18] or amplitude word[31:22]								N/A
Channel Word 7 (CW7) (0x10)	[31:0]	Frequency tuning word[31:0] or phase word[31:18] or amplitude word[31:22]								N/A
Channel Word 8 (CW8) (0x11)	[31:0]	Frequency tuning word[31:0] or phase word[31:18] or amplitude word[31:22]								N/A
Channel Word 9 (CW9) (0x12)	[31:0]	Frequency tuning word[31:0] or phase word[31:18] or amplitude word[31:22]								N/A
Channel Word 10 (CW10) (0x13)	[31:0]	Frequency tuning word[31:0] or phase word[31:18] or amplitude word[31:22]								N/A
Channel Word 11 (CW11) (0x14)	[31:0]	Frequency tuning word[31:0] or phase word[31:18] or amplitude word[31:22]								N/A
Channel Word 12 (CW12) (0x15)	[31:0]	Frequency tuning word[31:0] or phase word[31:18] or amplitude word[31:22]								N/A
Channel Word 13 (CW13) (0x16)	[31:0]	Frequency tuning word[31:0] or phase word[31:18] or amplitude word[31:22]								N/A
Channel Word 14 (CW14) (0x17)	[31:0]	Frequency tuning word[31:0] or phase word[31:18] or amplitude word[31:22]								N/A
Channel Word 15 (CW15) (0x18)	[31:0]	Frequency tuning word[31:0] or phase word[31:18] or amplitude word[31:22]								N/A

¹ Each channel word register has a capacity of 32 bits. If phase or amplitude is stored in the channel word registers, it must be first MSB aligned per the bit range. Only the MSB byte is shown for each channel word register.

DESCRIPTIONS FOR CONTROL REGISTERS

Channel Select Register (CSR)—Address 0x00

One byte is assigned to this register.

The CSR determines if channels are enabled or disabled by the status of the two channel enable bits. Both channels are enabled by their default state. The CSR also determines which serial mode of operation is selected. In addition, the CSR offers a choice of MSB first or LSB first format.

Table 31. Bit Descriptions for CSR

Bit	Mnemonic	Description
7:6	Channel [1:0] enable	Bits are active immediately after being written. They do not require an I/O update to take effect. There are two sets of channel registers and profile (channel word) registers, one per channel. This is not shown in the channel register map or the profile register map. The addresses of all channel registers and profile registers are the same for each channel. Therefore, the channel enable bits distinguish the channel registers and profile registers values of each channel. For example, 10 = only Channel 1 receives commands from the channel registers and profile registers. 01 = only Channel 0 receives commands from the channel registers and profile registers. 11 = both Channel 0 and Channel 1 receive commands from the channel registers and profile registers.
5:4	Open	
3	Must be 0	Must be set to 0.
2:1	Serial I/O mode select	00 = single-bit serial (2-wire mode). 01 = single-bit serial (3-wire mode). 10 = 2-bit serial mode. 11 = 4-bit serial mode. See the Serial I/O Modes of Operation section for more details.
0	LSB first	0 = the serial interface accepts serial data in MSB first format (default). 1 = the serial interface accepts serial data in LSB first format.

Function Register 1 (FR1)—Address 0x01

Three bytes are assigned to this register. FR1 is used to control the mode of operation of the chip.

Table 32. Bit Descriptions for FR1

Bit	Mnemonic	Description
23	VCO gain control	0 = the low range (system clock below 160 MHz) (default). 1 = the high range (system clock above 255 MHz).
22:18	PLL divider ratio	If the value is 4 or 20 (decimal) or between 4 and 20, the PLL is enabled and the value sets the multiplication factor. If the value is outside of 4 and 20 (decimal), the PLL is disabled.
17:16	Charge pump control	00 (default) = the charge pump current is 75 μ A. 01 = charge pump current is 100 μ A. 10 = charge pump current is 125 μ A. 11 = charge pump current is 150 μ A.
15	Open	
14:12	Profile pin configuration (PPC)	The profile pin configuration bits control the configuration of the data and SDIO_x pins for the different modulation modes. See the Modulation Mode section in this document for details.
11:10	Ramp-up/ramp-down (RU/RD)	The RU/RD bits control the amplitude ramp-up/ramp-down time of a channel. See the Output Amplitude Control Mode section for more details.
9:8	Modulation level	The modulation (FSK, PSK, and ASK) level bits control the level (2/4/8/16) of modulation to be performed for a channel. See the Modulation Mode section for more details.
7	Reference clock input power-down	0 = the clock input circuitry is enabled for operation (default). 1 = the clock input circuitry is disabled and is in a low power dissipation state.

AD9958

Bit	Mnemonic	Description
6	External power-down mode	0 = the external power-down mode is in fast recovery power-down mode (default). In this mode, when the PWR_DWN_CTL input pin is high, the digital logic and the DAC digital logic are powered down. The DAC bias circuitry, PLL, oscillator, and clock input circuitry are not powered down. 1 = the external power-down mode is in full power-down mode. In this mode, when the PWR_DWN_CTL input pin is high, all functions are powered down. This includes the DAC and PLL, which take a significant amount of time to power up.
5	SYNC_CLK disable	0 = the SYNC_CLK pin is active (default). 1 = the SYNC_CLK pin assumes a static Logic 0 state (disabled). In this state, the pin drive logic is shut down. However, the synchronization circuitry remains active internally to maintain normal device operation.
4	DAC reference power-down	0 = DAC reference is enabled (default). 1 = DAC reference is powered down.
3:2	Open	See the Synchronizing Multiple AD9958 Devices section for details.
1	Manual hardware sync	0 = the manual hardware synchronization feature of multiple devices is inactive (default). 1 = the manual hardware synchronization feature of multiple devices is active.
0	Manual software sync	0 = the manual software synchronization feature of multiple devices is inactive (default). 1 = the manual software synchronization feature of multiple devices is active. See the Synchronizing Multiple AD9958 Devices section for details.

Function Register 2 (FR2)—Address 0x02

Two bytes are assigned to this register. The FR2 is used to control the various functions, features, and modes of the AD9958.

Table 33. Bit Descriptions for FR2

Bit	Mnemonic	Description
15	All channels autoclear sweep accumulator	0 = a new delta word is applied to the input, as in normal operation, but not loaded into the accumulator (default). 1 = this bit automatically and synchronously clears (loads 0s into) the sweep accumulator for one cycle upon reception of the I/O_UPDATE sequence indicator on both channels.
14	All channels clear sweep accumulator	0 = the sweep accumulator functions as normal (default). 1 = the sweep accumulator memory elements for both channels are asynchronously cleared.
13	All channels autoclear phase accumulator	0 = a new frequency tuning word is applied to the inputs of the phase accumulator, but not loaded into the accumulator (default). 1 = this bit automatically and synchronously clears (loads 0s into) the phase accumulator for one cycle upon receipt of the I/O update sequence indicator on both channels.
12	All channels clear phase Accumulator	0 = the phase accumulator functions as normal (default). 1 = the phase accumulator memory elements for both channels are asynchronously cleared.
11:8	Open	
7	Auto sync enable	See the Synchronizing Multiple AD9958 Devices section for more details.
6	Multidevice sync master enable	See the Synchronizing Multiple AD9958 Devices section for more details.
5	Multidevice sync status	See the Synchronizing Multiple AD9958 Devices section for more details.
4	Multidevice sync mask	See the Synchronizing Multiple AD9958 Devices section for more details.
3:2	Open	
1:0	System clock offset	See the Synchronizing Multiple AD9958 Devices section for more details.

DESCRIPTIONS FOR CHANNEL REGISTERS**Channel Function Register (CFR)—Address 0x03**

Three bytes are assigned to this register.

Table 34. Bit Descriptions for CFR

Bit	Mnemonic	Description
23:22	Amplitude frequency phase (AFP) select	Controls what type of modulation is to be performed for that channel. See the Modulation Mode section for details.
21:16	Open	
15	Linear sweep no-dwell	0 = the linear sweep no-dwell function is inactive (default). 1 = the linear sweep no-dwell function is active. If CFR[15] is active, the linear sweep no-dwell function is activated. See the Linear Sweep Mode section for details. If CFR[14] is clear, this bit is don't care.
14	Linear sweep enable	0 = the linear sweep capability is inactive (default). 1 = the linear sweep capability is enabled. When enabled, the delta frequency tuning word is applied to the frequency accumulator at the programmed ramp rate.
13	Load SRR at I/O_UPDATE	0 = the linear sweep ramp rate timer is loaded only upon timeout (timer = 1) and is not loaded because of an I/O_UPDATE input signal (default). 1 = the linear sweep ramp rate timer is loaded upon timeout (timer = 1) or at the time of an I/O_UPDATE input signal.
12:11	Open	
10	Must be 0	Must be set to 0.
9:8	DAC full-scale current control	11 = the DAC is at the largest LSB value (default). See Table 5 for other settings.
7	Digital power-down	0 = the digital core is enabled for operation (default). 1 = the digital core is disabled and is in its lowest power dissipation state.
6	DAC power-down	0 = the DAC is enabled for operation (default). 1 = the DAC is disabled and is in its lowest power dissipation state.
5	Matched pipe delays active	0 = matched pipe delay mode is inactive (default). 1 = matched pipe delay mode is active. See the Single-Tone Mode—Matched Pipeline Delay section for details.
4	Autoclear sweep accumulator	0 = the current state of the sweep accumulator is not impacted by receipt of an I/O_UPDATE signal (default). 1 = the sweep accumulator is automatically and synchronously cleared for one cycle upon receipt of an I/O_UPDATE signal.
3	Clear sweep accumulator	0 = the sweep accumulator functions as normal (default). 1 = the sweep accumulator memory elements are asynchronously cleared.
2	Autoclear phase accumulator	0 = the current state of the phase accumulator is not impacted by receipt of an I/O_UPDATE signal (default). 1 = the phase accumulator is automatically and synchronously cleared for one cycle upon receipt of an I/O_UPDATE signal.
1	Clear phase accumulator	0 = the phase accumulator functions as normal (default). 1 = the phase accumulator memory elements are asynchronously cleared.
0	Sine wave output enable	0 = the angle-to-amplitude conversion logic employs a cosine function (default). 1 = the angle-to-amplitude conversion logic employs a sine function.

AD9958

Channel Frequency Tuning Word 0 (CFTW0)—Address 0x04

Four bytes are assigned to this register.

Table 35. Description for CFTW0

Bit	Mnemonic	Description
31:0	Frequency Tuning Word 0	Frequency Tuning Word 0 for each channel.

Channel Phase Offset Word 0 (CPOW0)—Address 0x05

Two bytes are assigned to this register.

Table 36. Description for CPOW0

Bit	Mnemonic	Description
15:14	Open	
13:0	Phase Offset Word 0	Phase Offset Word 0 for each channel.

Amplitude Control Register (ACR)—Address 0x06

Three bytes are assigned to this register.

Table 37. Description for ACR

Bit	Mnemonic	Description
23:16	Amplitude ramp rate	Amplitude ramp rate value.
15:14	Increment/decrement step size	Amplitude increment/decrement step size.
13	Open	
12	Amplitude multiplier enable	0 = amplitude multiplier is disabled. The clocks to this scaling function (auto RU/RD) are stopped for power saving, and the data from the DDS core is routed around the multipliers (default). 1 = amplitude multiplier is enabled.
11	Ramp-up/ramp-down enable	This bit is valid only when ACR[12] is active high. 0 = when ACR[12] is active, Logic 0 on ACR[11] enables the manual RU/RD operation. See the Output Amplitude Control Mode section for details (default). 1 = if ACR[12] is active, a Logic 1 on ACR[11] enables the auto RU/RD operation. See the Output Amplitude Control Mode section for details.
10	Load ARR at I/O_UPDATE	0 = the amplitude ramp rate timer is loaded only upon timeout (timer = 1) and is not loaded due to an I/O_UPDATE input signal (default). 1 = the amplitude ramp rate timer is loaded upon timeout (timer = 1) or at the time of an I/O_UPDATE input signal.
9:0	Amplitude scale factor	Amplitude scale factor for each channel.

Linear Sweep Ramp Rate (LSRR)—Address 0x07

Two bytes are assigned to this register.

Table 38. Description for LSRR

Bit	Mnemonic	Description
15:8	Falling sweep ramp rate (FSRR)	Linear falling sweep ramp rate.
7:0	Rising sweep ramp rate (RSRR)	Linear rising sweep ramp rate.

LSR Rising Delta Word (RDW)—Address 0x08

Four bytes are assigned to this register.

Table 39. Description for RDW

Bit	Mnemonic	Description
31:0	Rising delta word	32-bit rising delta-tuning word.

LSR Falling Delta Word (FDW)—Address 0x09

Four bytes are assigned to this register.

Table 40. Description for FDW

Bit	Mnemonic	Description
31:0	Falling delta word	32-bit falling delta-tuning word.

OUTLINE DIMENSIONS

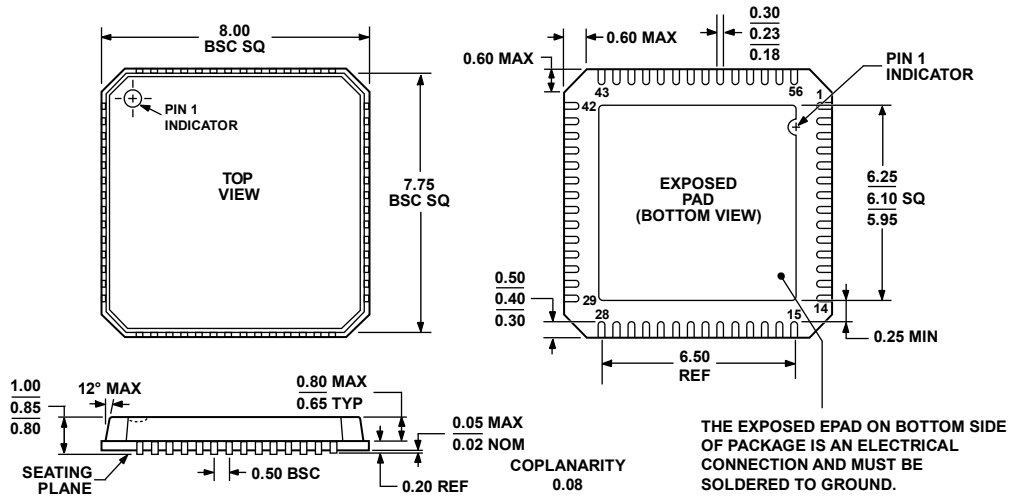

COMPLIANT TO JEDEC STANDARDS MO-220-VLLD-2

Figure 50. 56-Lead Lead Frame Chip Scale Package [LFCSP_VQ]
 8 mm × 8 mm Body, Very Thin Quad
 (CP-56-1)
 Dimensions shown in millimeters

051008-A

ORDERING GUIDE

Model	Temperature Range	Package Description	Package Option
AD9958BCPZ ¹	-40°C to +85°C	56-Lead Lead Frame Chip Scale Package [LFCSP_VQ]	CP-56-1
AD9958BCPZ-REEL7 ¹	-40°C to +85°C	56-Lead Lead Frame Chip Scale Package [LFCSP_VQ]	CP-56-1
AD9958/PCBZ ¹		Evaluation Board	

¹ Z = RoHS Compliant Part.